

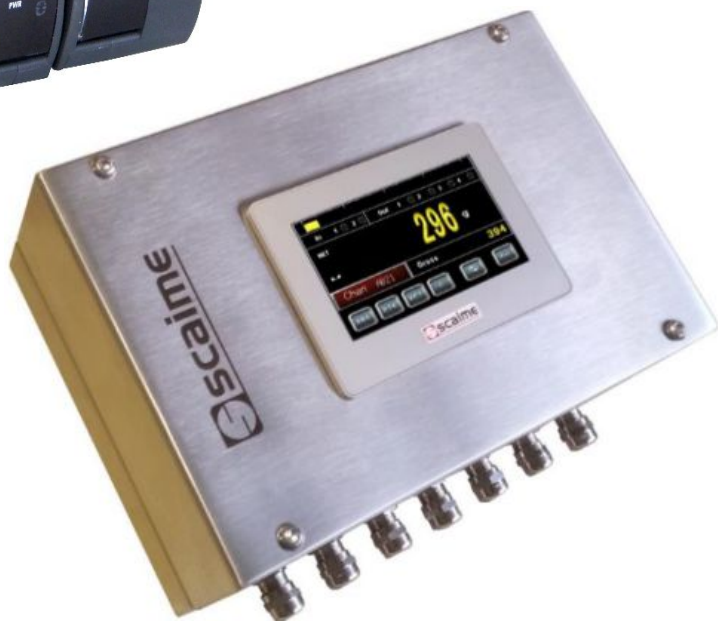

eNod4-B ETHERNET

Digital Process Transmitter



1	SAFETY INSTRUCTIONS	5
1.1	Getting started	5
1.2	Protection	6
1.3	Power supply	6
1.4	Grounding	6
1.5	Installation	6
1.6	Maintenance	6
1.7	Caution	6
2	ENOD4 PRODUCT RANGE	7
2.1	General presentation	7
2.2	Versions	7
2.2.1	Communication protocol versions	7
2.2.2	IO+ version	7
2.2.3	Bluetooth® version	7
2.3	eNodView Software	8
2.4	eNodApp - Mobile Application	8
3	GENERAL CHARACTERISTICS	9
3.1	Dimensions	9
3.2	Electrical characteristics	11
3.3	Legal for trade	12
4	CONNECTIONS	14
4.1	Cabling basic rules	15
4.1.1	Prevent Electrostatic Discharges	15
4.1.2	Prevent Electromagnetic disturbances	16
4.2	Power supply connection	17
4.3	Load-cell wiring	17
4.4	IO+ version	17
4.5	Inputs / outputs connections	18
4.5.1	Typical connections	19
4.6	JB4 option	19
4.6.1	Specifications	20
4.6.2	Excitation trimming procedure	20
4.6.3	Spring terminal connections	21
4.7	220V option	21
5	COMMUNICATION	22
5.1	Communication Interface connections	22
5.1.1	Process control communication	22
5.1.2	PC communication	22
5.1.3	AUX Communication (for HMI)	22
5.2	Communication address selection	22
5.3	Communication rate selection	23
5.4	Communication protocols	23
5.5	Simultaneous functioning of communications	24
5.6	Bluetooth® Communication (Optional)	25
6	CALIBRATION AND SCALE ADJUSTMENT	26
6.1	Physical calibration	26
6.2	Theoretical calibration	26
6.3	Scale adjustment coefficient	26
6.4	Gravity correction	26
6.5	Scale interval	26
7	FILTERS	27

7.1	Filtering related to the A/D conversion rate	27
7.2	Bessel low pass filter	27
7.3	Notch filter	27
7.4	Moving average filter	27
8	MEASUREMENT AND STATUS	28
8.1	Gross measurement	28
8.2	Net measurement.....	28
8.3	Tare value.....	28
8.4	Factory calibrated points	28
8.5	Logical IN/OUT level.....	28
8.6	Preset Tare value	28
8.7	Measurement status	28
8.8	Weighing diagnosis	28
8.8.1	Global weighing diagnosis	28
8.8.2	Sensor input control	28
9	INPUTS FUNCTIONING	29
9.1	Inputs assignment:.....	29
9.2	General functions	29
9.2.1	None	29
9.2.2	Tare	29
9.2.3	Cancel tare	29
9.2.4	Zero	29
9.2.5	Transmit measurement	29
9.2.6	Measurement window	30
9.2.7	Sensor input control	30
9.3	Functions attached to an operating mode:	30
10	OUTPUTS FUNCTIONING	31
10.1	Outputs assignment:.....	31
10.2	General functions:	31
10.2.1	None:	31
10.2.2	Set point:	31
10.2.3	Motion:.....	32
10.2.4	Defective measurement:.....	32
10.2.5	Input image:	32
10.2.6	Level on request:	32
10.3	Functions attached to an operating mode:	32
10.4	Optional analog output (IO+ version)	32
11	BELT WEIGHER OPERATING MODE	34
11.1	Introduction and Overview.....	34
11.2	Totalization cycle description	35
11.2.1	Cycle options.....	35
•	Batch mode	35
•	Clear totalization	35
•	PID Activation	35
11.2.2	Weight section length (mm).....	36
11.2.3	Conveyor inclination (degrees).....	36
11.2.4	Minimum load to totalize (weight unit/meter).....	37
11.2.5	Pulses factor speed sensor (Pulses/meter)	37
11.2.6	Measurement time factor for speed (x250ms).....	37
11.2.7	Constant belt speed (m/s)	37
11.2.8	Flow correction factor.....	37

11.3 Belt calibration.....	37
11.3.1 Speed sensor calibration.....	37
11.3.2 Static weight calibration.....	38
11.3.3 Material Test (Dynamic weight calibration or correction factor) ...	38
11.4 Calibration of flow rate	38
11.5 Totalization	38
11.6 Alarms.....	39
11.6.1 Minimum flow rate limit value (0.1%)	39
11.6.2 Maximum flow rate limit value (0.1%).....	39
11.6.3 Minimum belt load limit value (0.1%).....	39
11.6.4 Maximum belt load limit value (0.1%)	39
11.6.5 Minimum control output limit value (0.1%).....	39
11.6.6 Maximum control output limit value (0.1%).....	39
11.6.7 Minimum belt speed limit value (0.1%).....	40
11.6.8 Maximum belt speed limit value (0.1%)	40
11.6.9 Inhibit time of speed alarms at start (ms)	40
11.6.10 Inhibit time of speed alarms in service (ms).....	40
11.6.11 Errors counter	40
11.7 Inputs assignments	40
• Start / Stop dosing (and batch)	41
• Belt running motion detection.....	41
• Clear/Reset totalization and errors counter.....	41
• Dynamic zero.....	41
• Belt Fault	41
12 ENODTOUCH – HUMAN MACHINE INTERFACE (OPTION)	42
12.1 Online functioning	42
12.1.1 Startup screens	42
12.1.2 Multi-eNod screens.....	43
12.1.3 Main screen	47
12.1.4 Main setup menu	50
12.2 Belt parameter configuration (eNod4-B)	70
12.2.1 Flow Rate	71
12.2.2 Dosing Alarms.....	72
12.2.3 Conveyor	74
12.2.4 Speed	75
12.2.5 Batch dosing.....	76
12.2.6 PID	77
12.2.7 Flow Rate Calibration.....	78

1 SAFETY INSTRUCTIONS

Important information

Be sure to read this manual thoroughly before starting the PRODUCT. This manual is part of the PRODUCT and comes with it. Rules for the prevention of risks and accidents as well as safety rules must be observed!

The PRODUCT is manufactured in accordance with the current state of the art and in accordance with safety regulations laws of the Labour Code.

The general safety requirements must be observed during all phases of operation and repair of equipment. Non-compliance of written warnings in this manual is contrary to the requirements of safe operation and normal operation of the PRODUCT.

As a user of this product, it is necessary to strictly follow in your work environment, all warnings and requirements necessary to perform safely any operation on the PRODUCT.



This symbol means that there is a risk of electrification that can lead to death or serious injuries if instructions are not followed.



This symbol means that there is a risk of danger that can lead to injuries if safety instructions are not followed.



Earth protection connection



WEEE 2002/96/CE Waste of electrical and electronic equipment directive imposes to final users the management of electrical and electronic equipment (EEE). For the purpose, it is mandatory for them to selectively collect their EEE depositing them in dedicated places.



DANGER

Danger: dangerous situation that can lead immediately to death or serious injuries.



WARNING

Warning: situation potentially dangerous that could lead to death.



CAUTIOUS

Cautious: situation potentially dangerous that could lead to injuries.

1.1 Getting started



WARNING

Security provided by this product is provided for use for its intended purpose. Maintenance can only be performed by qualified staff.

1.2 Protection



WARNING

The PRODUCT, with 220V option, must be linked to a protection device. This one must comply to the standards in force in the country (NFC 15-100 in France) and must be part of the building in which the PRODUCT has been installed. The circuit breaker must be 16 Amps and should have a response curve of type C.



WARNING

The mains plug of the PRODUCT serves as disconnecting device. Consequently, it must be connected near the device and easily accessible.

1.3 Power supply



WARNING

The PRODUCT, with 24VDC version, must be powered by a power supply in accordance to EN 60950-1. It must be located close to the PRODUCT.

1.4 Grounding



DANGER

To minimize any risk of electric shock, frame and all parts of the equipment must be connected to Earth.

1.5 Installation

The PRODUCT must be fitted on a support by using the mounting brackets at the rear of the box.

1.6 Maintenance

The PRDUCT can be cleaned using a damp slightly cloth.



DANGER

For your safety, before any technical intervention or cleaning, it is imperative that the equipment is turned off and not plugged in. It is forbidden to replace components with power cable connected.

1.7 Caution

When installing, moving, or handling this product or peripherals connected to it, refer to the instructions below to connect and disconnect the various cords.

Connection:	Disconnection:
<ol style="list-style-type: none">1. Turn off the units.2. Start by connecting all cords to the units.3. Connect the interface cables to the connectors.4. Connect the power cords into outlet.5. Turn on the units.	<ol style="list-style-type: none">1. Turn off the units.2. Disconnect the power cords from the outlets.3. Disconnect the interface cables from the connectors.4. Disconnect all cabled from the units.

2 ENOD4 PRODUCT RANGE

2.1 General presentation

eNod4 is a high speed digital process transmitter with programmable functions and powerful signal processing capabilities. **eNod4** offers operating modes for advanced process control both static and dynamic.

Quick and accurate:

- Analog to digital conversion rate up to 1920 meas/s with maximum scaled resolution of $\pm 500\,000$ points.
- Digital filtering and measurement scaling.
- Measurement transmission up to 1 000 meas/s.

Easy to integrate into automated system:

- **USB, RS485** and **CAN** communication interfaces supporting **ModBus RTU**, **CANopen®** and **PROFIBUS-DPV1** (depending on version) communication protocols.
- Digital Inputs/Outputs for process control.
- Setting of node number by rotary switches and communication baud rate by dip switches.
- Integrated selectable network termination resistors.
- Wiring by plug-in terminal blocs.

2.2 Versions

2.2.1 Communication protocol versions

- Strain gauges load-cell conditioner with **CANopen®** and **ModBus RTU** communication.
- Strain gauges load-cell conditioner with **Profibus DP-V1** and **ModBus RTU** communication.
- Strain gauges load-cell conditioner with **Modbus TCP** and **ModBus RTU** communication.
- Strain gauges load-cell conditioner with **EtherNet/IP** and **ModBus RTU** communication.
- Strain gauges load-cell conditioner with **Profinet IO** and **ModBus RTU** communication.
- Strain gauges load-cell conditioner with **EtherCAT** and **ModBus RTU** communication.

EDS, GSD, ESI and GSDML configuration files for above protocols can be downloaded from our web site: <http://www.scaime.com>

2.2.2 IO+ version

In conjunction with all communication protocol versions, **eNod4** can supports an opto-insulated board fitted with:

- 2 additional digital inputs and 1 speed sensor dedicated input.
- 0-5V or 0-10V analog output voltage.
- 4-20mA, 0-24mA, 0-20mA or 4-20mA with alarm at 3.6mA analog output current.

2.2.3 Bluetooth® version

In conjunction with all communication protocol versions and IO+ version, **eNod4** can supports a communication board that allows to exchange information via Bluetooth®.

Radio information	
Wireless communication	Bluetooth® Low Energy 4.2
Max. RF output power	-16.9 dBm
Frequency range	2.4 – 2.4835 GHz

2.3 eNodView Software

So as to configure **eNod4**, SCAIME provides eNodView software tool. **eNodView** is the software dedicated to eNod devices and digital load cell configuration from a PC. This simple graphical interface allows accessing the whole functionalities of **eNod4** for a complete setting according to the application.

eNodView features and functions:

- eNod4 control from a PC
- Calibration system
- Modification/record of all parameters
- Measure acquisition with graphical display
- Numerical filters simulation
- Frequential analysis FFT
- Process control
- Network parameter

eNodView software is available in English and French version and can be downloaded from our web site: <http://www.scaime.com> or ordered to our sales department on a CD-ROM support.

2.4 eNodApp - Mobile Application

So as to configure **eNod4**, SCAIME provides eNodApp application through the **Google Play Store**. **eNodApp** is the application dedicated to eNod devices (fitted with the Bluetooth® option) configuration from an Android device. This simple graphical interface allows accessing most of the functionalities of **eNod4** for a quick setting according to the application.

eNodApp features and functions:

- eNod4 control from an Android device
- Calibration system
- Modification/record of all parameters

eNodApp application is available in English and French version and can be downloaded from the [Google Play Store](#).

3 GENERAL CHARACTERISTICS

3.1 Dimensions

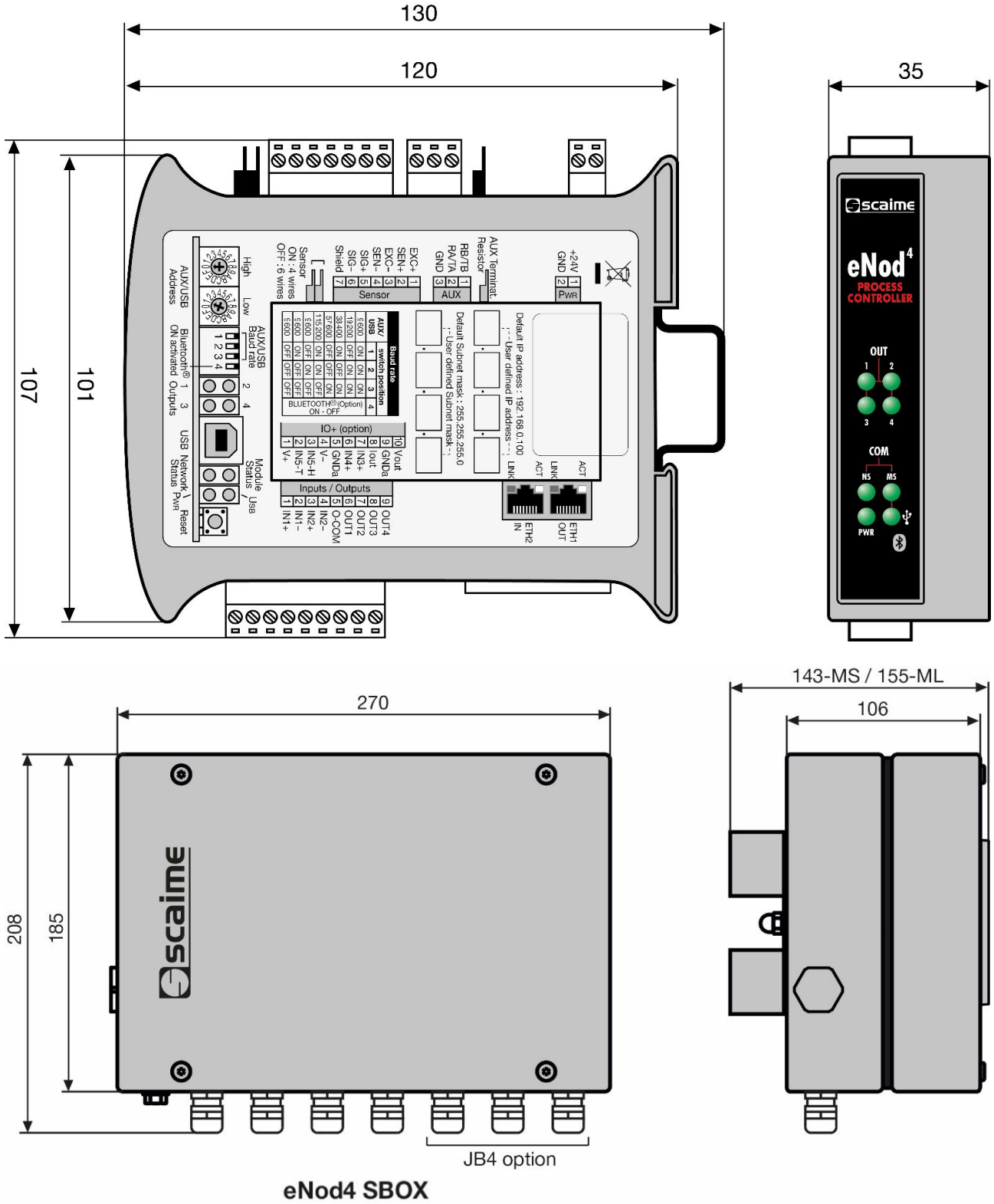

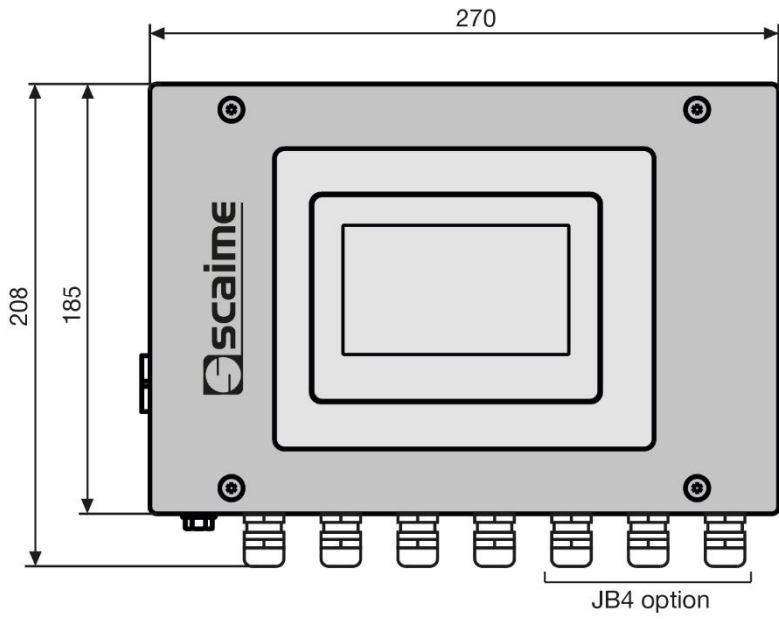

eNod4 SBOX-MS/ML

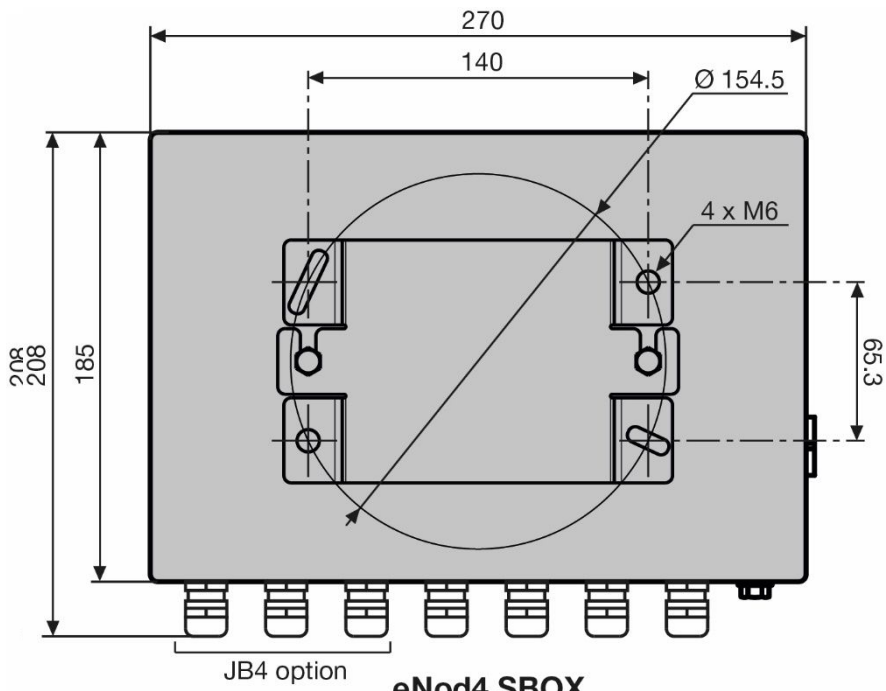
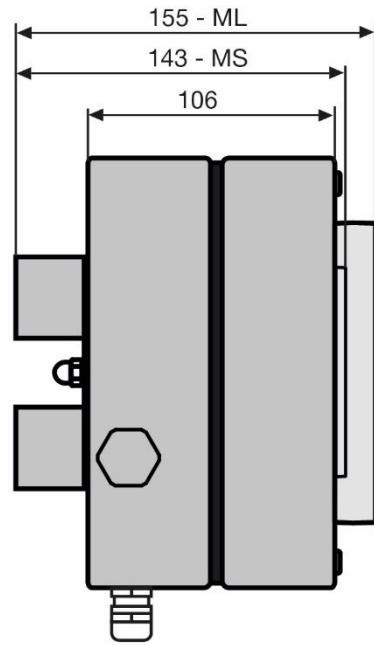

eNod4 SBOX

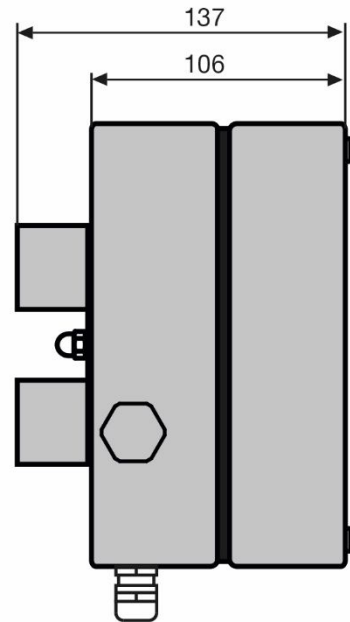

3.2 Electrical characteristics

Power supply		Unit
Supply voltage	10....28	V _{DC}
	110....240	V _{AC}
Max supply power	4.4	W
Additional max supply power (IO+ version)	3	W
Temperature range		
Storage temperature range	-25...+85	°C
Working temperature range	-10...+40	°C
Load cell sensor		
Minimum input resistance	> 43	Ω
sensor connection	4 or 6 wires	
Bridge excitation voltage	5	V _{DC}
Communication		
RS 485	Half-duplex	
Rate	9 600...115 200	bauds
Ethernet 2 x RJ45	10/100	Mbits/s
Logical inputs		
Number	2 (+2 with IO+ version)	
Type	opto-insulated type 3	
Low level voltage-current	0 / 5 VDC – 0 / 1.5 mA	
High level voltage-current	11 / 30 VDC – 2 / 9 mA 7 mA @ 24VDC	
Logical outputs		
Number	4	
Type	solid state relay	
Max. current @ 40°C	0,4	A
Max. voltage in open state	53 V _{DC} or 37 V _{AC}	
Max resistor in close state	2	Ω
Metrological specifications on A3 connector input (load-cell type sensor)		
Input sensor range for a load cell sensor	± 7.8	mV/V
Thermal zero drift typical	1.5	ppm/°C
Thermal span drift typical	2	ppm/°C
Linearity deviation	0.003	% FS
Conversion rate	6.25 ... 1920	meas./s

Metrological specifications on analog output (IO+ version)		
Output voltage range	0-5 or 0-10	V
Output current range	4-20, 0-24 ou 0-20	mA
Max. load on current output	500	Ohm
Outputs resolution	16	bit
Max. linearity error	1	LSB
Total error	+/- 0.07	%FSR
Thermal zero drift typical	+/- 2	ppm/°C
Thermal span drift typical	+/- 3	ppm/°C
Conversion rate	A/D converter rate value	Hz
Speed sensor power-supply (IO+ version)		
Bridge excitation voltage (V+ ...V-)	12.5 +/- 2	V
Bridge excitation current	30	mA
Isolation	1000	V
Speed sensor input (IO+ version)		
IN5 HTL	0...2.5 / 5...30	VDC
IN5 TTL	0...0.5 / 2.4...5	VDC
Isolation	1000	V

3.3 Legal for trade

Characteristics		Unit
Accuracy class	III or IIII	
Maximum number of weighing ranges	1	
Maximum number of verification scale divisions	6000	
Load cell(s) excitation voltage	5	V
Minimum voltage division per verification scale division (ΔU_{min})	0.5	μV
Minimum voltage of the weighing range	$0.5 * n * 10^{-3}$	mV
Maximum voltage of the weighing range	39	mV
Value of factor p_i	0.5	
Minimum impedance for the load cell	47	Ohm
Type of load cell(s) connection system	4-wire or 6-wire	
Maximum impedance for the load cell	1500	Ohm
Maximal length/section measurement cable	166	m/mm ²

eNod4* is an analog data processing unit evaluated as a part of a non-automatic weighing instrument (NAWI) with applicative software -T or an automatic weighing instrument (AWI) like an automatic gravimetric filling instrument with applicative software -D or a catchweigher with applicative software -C. This instrument is not intended for direct sales to the public. It is suitable for conditioning OIML R60 certified strain gauges load cell(s) with analog output.

Legal for trade mode has to be activated internally in order to respect metrological requirements. All the functionalities will be conformed to the essential requirements for certified weighing instruments.

Sealing will be material on the eNod4 housing and load cell connections. If a junction box is used it will have to be sealed too.

eNod4 is fitted with a software sealing for metrological parameters and once activated, is composed of an event counter and a CRC value of specific and adjustment parameters. These values shall be marked on the terminal device connected after the last official verification when putting in service the instrument. Any mismatch between the displayed values on the terminal and those marked will signify a broken sealing.

eNod4 is fitted with a data storage device (DSD) so called alibi memory. Any weighing result (or checkweigher result with applicative software -C, or dosing result with applicative software -D) is stored internally and can be recalled on demand. 130816 records can be stored permanently at maximum. Any record is identified by a unique 32-bit long number. This identifier is incremented each time a weighing result is stored and transmitted.

The minimum time between two DSD recording operations is 50ms.

* legal for trade use does not apply to software applicative for beltweigher (-B) and weigh feeder (-F)

4 CONNECTIONS

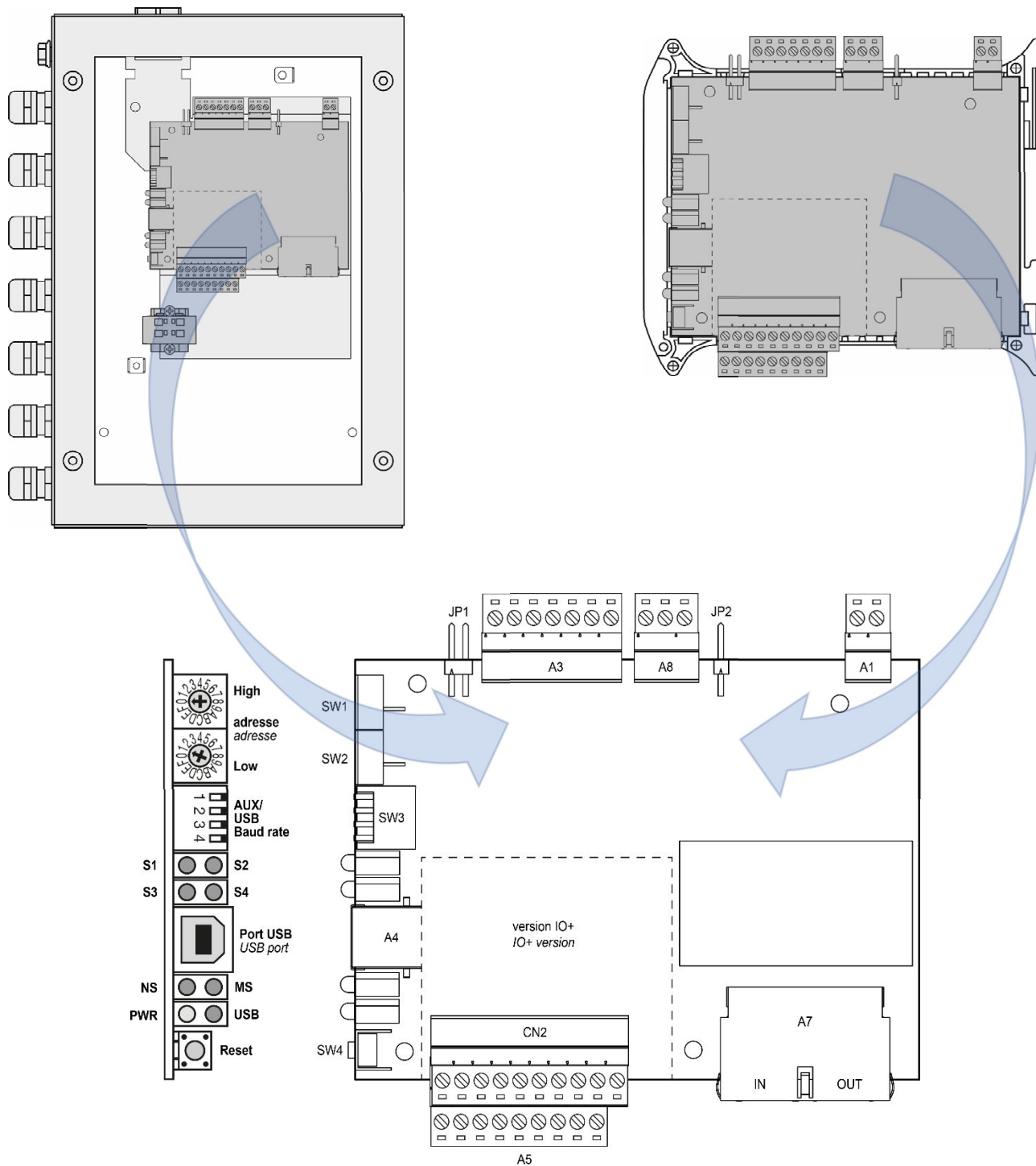

Repère Mark	Fonction Function		Repère Mark	Fonction Function			
A1 alimentation power supply	1	+V _{DC}	JP1	Câblage capteur 6 fils / 4 fils 6-wire / 4-wire loadcell wiring			
	2	GND		JP2	Résistance de terminaison connexion AUX AUX connection termination resistor		
A3 connexion capteur load cell connection	1	Exc+	A8 connexion AUX AUX connection		1	RB/TB (B-)	
	2	Sens+			2	RA/TA (A+)	
	3	Exc-			3	GND	
	4	Sens-			CN2	1	V+
	5	Sig+				2	INS-HTL
	6	Sig-					
	7	Shield					

A4	<i>Port USB</i>		Connexion IO+ IO+ connection	3	<i>IN5-TTL</i>
A5 entrées/sorties IN / OUT	1	<i>IN1+</i>		4	<i>V-</i>
	2	<i>IN1-</i>		5	<i>GNDA</i>
	3	<i>IN2+</i>		6	<i>IN4+</i>
	4	<i>IN2-</i>		7	<i>IN3+</i>
	5	<i>OUT_{COM}</i>		8	<i>Iout</i>
	6	<i>OUT1</i>		9	<i>GNDA</i>
	7	<i>OUT2</i>		10	<i>Vout</i>
	8	<i>OUT3</i>			
	9	<i>OUT4</i>			
		SW1	Sélecteur Adresse haute (hex) <i>High Address selector (hex)Low</i>		
SW2	Sélecteur Adresse basse (hex) <i>Low Address selector (hex)</i>		A7 2 x RJ45 Ethernet	Ethernet ETH1 RJ45 (sortie) <i>Ethernet ETH1 RJ45 (output)</i>	
SW3	Sélecteur Baud rate AUX/USB <i>Aux/USB Baud rate selector</i>			Ethernet ETH2 RJ45 (entrée) <i>Ethernet ETH2 RJ45 (input)</i>	
SW4	bouton poussoir Reset <i>reset push button</i>		NS / MS	LED NS: Network Status (Bus Fault Profinet) LED MS: Module Status (System Fault Profinet)	
S1-S2-S3-S4	LED sorties logiques <i>outputs LED</i>		PWR-USB	LED alimentation & activité USB <i>power supply & USB activity LED</i>	

4.1 Cabling basic rules

4.1.1 Prevent Electrostatic Discharges

For ESD protection, cabling for the analog load cell must include a ferrite and a silicone protection sleeve, not included with the transmitter.

Install the ferrite by passing the analog cell connection through the ferrite and wrapping it around once, as shown on the following picture:

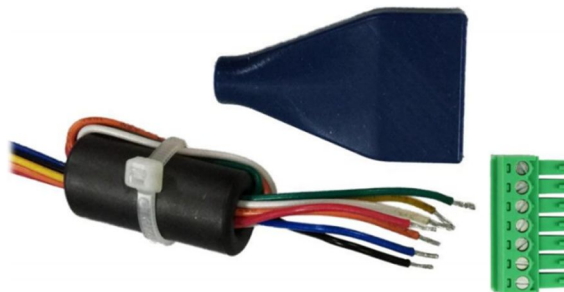

4.1.2 Prevent Electromagnetic disturbances

Observe these basic rules to guard against Electromagnetic disturbances.

Rule 1: Large area grounding contact

- When installing the devices, make sure that the surfaces of inactive metal parts are properly bonded to chassis ground (see following sections).
- Bond all inactive metal parts to chassis ground, ensuring large area and low-impedance contact (large cross-sections).
- When using screw connections on varnished or anodized metal parts, support contact with special contact washers or remove the protective insulating finish on the points of contact.
- Wherever possible, avoid the use of aluminium parts for ground bonding. Aluminium oxidizes very easily and is therefore less suitable for ground bonding.
- Provide a central connection between chassis ground and the ground/protective conductor system.

Rule 2: Proper cable routing

- Organize your wiring system into cable groups (high-voltage/power supply/signal/measurement/data cables).
- Always route high-voltage and data cables in separate ducts or in separate bundles.
- Install the measurement cables as close as possible to grounded surfaces (e.g. supporting beams, metal rails, steel cabinet walls).

Rule 3: Fixing the cable shielding

- Ensure proper fixation of the cable shielding.
- Always use shielded data cables. Always connect both ends of the data cable shielding to ground on a large area.
- Keep unshielded cable ends as short as possible.
- Always use metal/metalized connector housings only for shielded data cables.
- Shields of load cells must be connected to the pin 'Shield' of the load cell connector of the eNod4 or, in case of junction box, directly on the body of this one.

Rule 4: Special EMC measures

- For cabinet or enclosure lighting in the immediate range of your controller, use incandescent lamps or interference suppressed fluorescent lamps.

Rule 5: Homogeneous reference potential

- Create a homogeneous reference potential and ground all electrical equipment.

Use sufficiently dimensioned equipotential bonding conductors if potential differences exist or are expected between your system components.

Equipotential bonding is absolutely mandatory for applications in hazardous areas.

4.2 Power supply connection

1	+VDC	
2	GND	

A1

On the front panel a green light 'PWR', (D7) indicates if power is connected.

4.3 Load-cell wiring

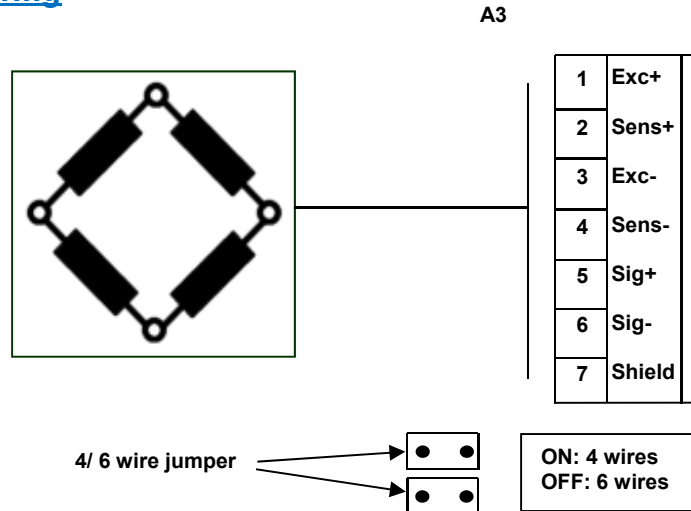

- **4 wires load-cell:** jumpers in place (by default at delivery).
- **6 wires load-cell:** jumpers removed

4.4 IO+ version

An analog board in current and voltage might be used with **eNod4** to provide IO+ version. This has to be requested when ordering **eNod4** product. The analog output is both current and voltage galvanically isolated at 1000V. *Voltage output* might be set either 0-5V or 0-10V, and the *current output* to 4-20mA, 0-24mA, 0-20mA or 4-20mA alarm 3.6mA. It is software setting and both output (current and voltage) might separately be enable.

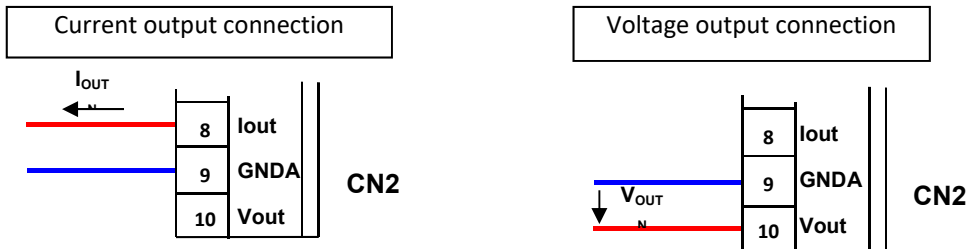

The IO+ version is fitted with two additional inputs IN3 and IN4:

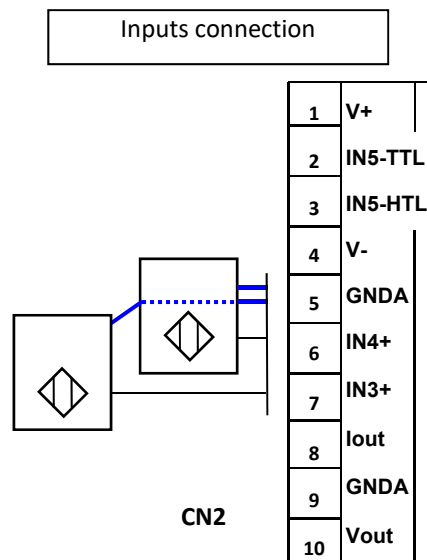

The IO+ version is fitted with a pulse input and a dedicated power supply for a speed sensor (belt weigh feeder, belt weigher). Two input voltage levels are proposed for the pulse input of the speed sensor: TTL logical level or high voltage 30 V maxi level.

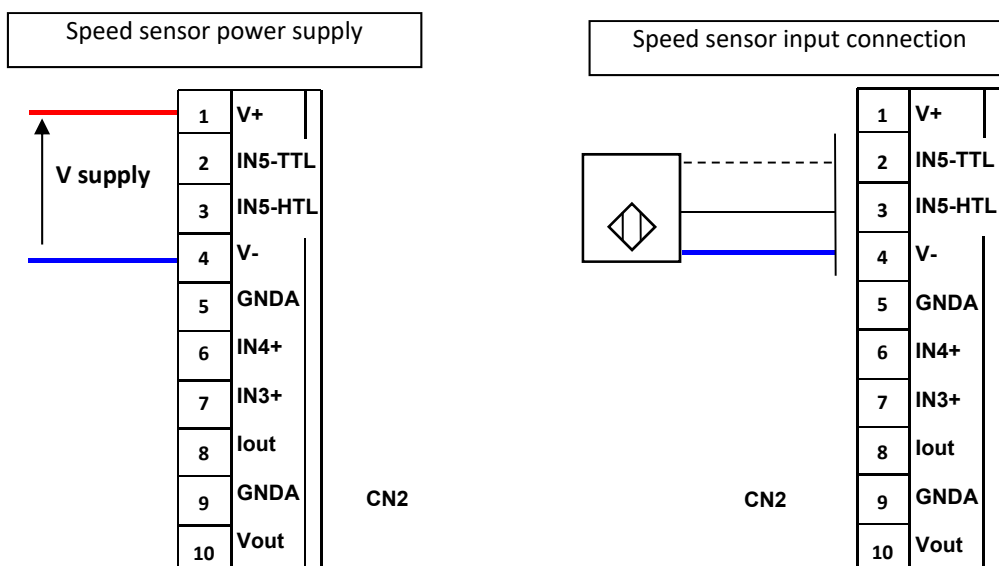

4.5 Inputs / outputs connections

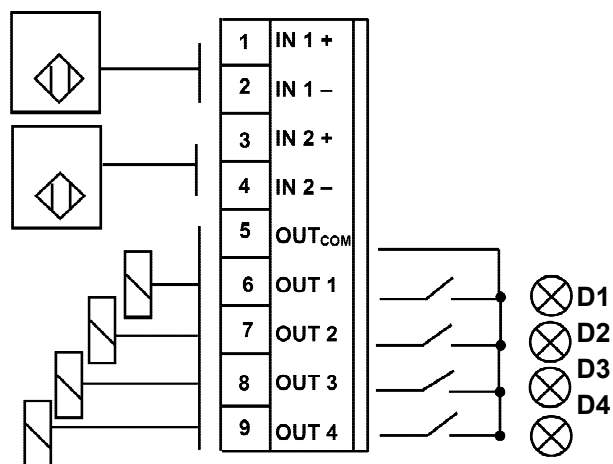

An indicator light in front panel is assigned to each Output.

4.5.1 Typical connections

Inputs : Connection to a detector

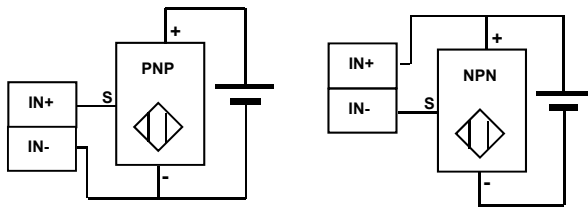

Inputs : Connection to a push button

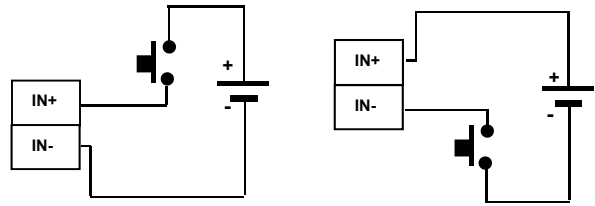

Outputs : Possible connections

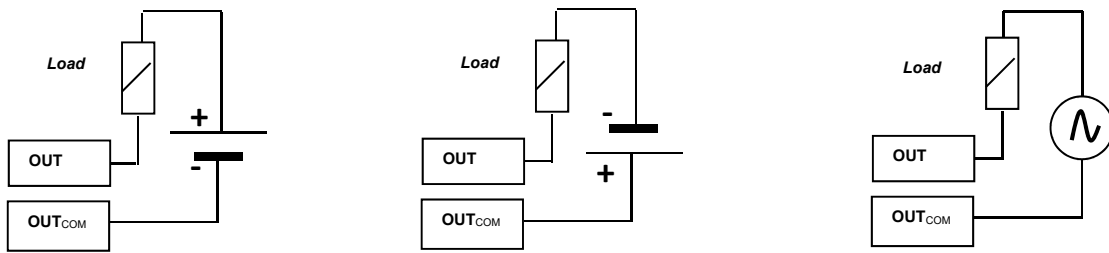

4.6 JB4 option

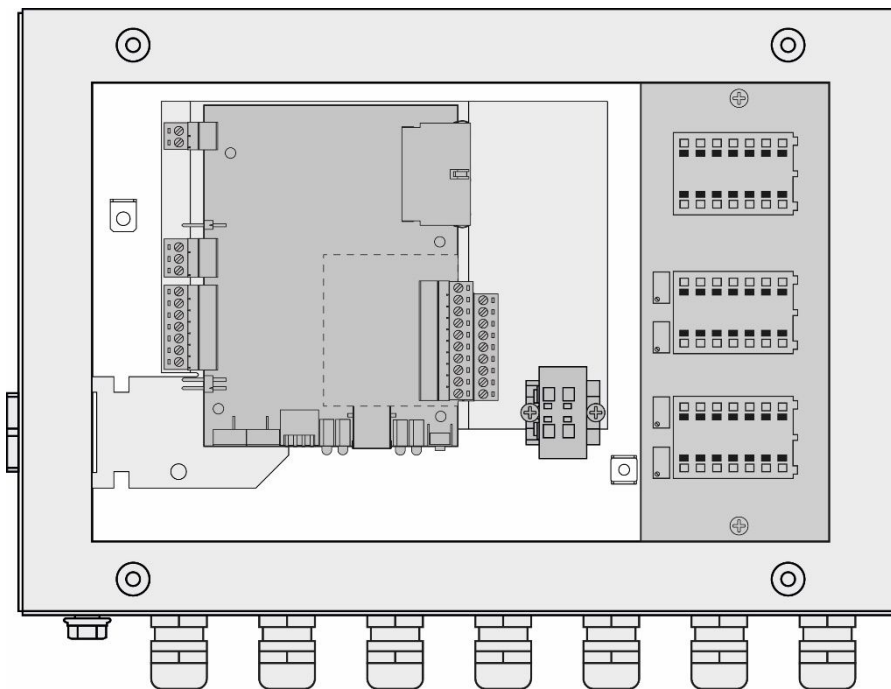

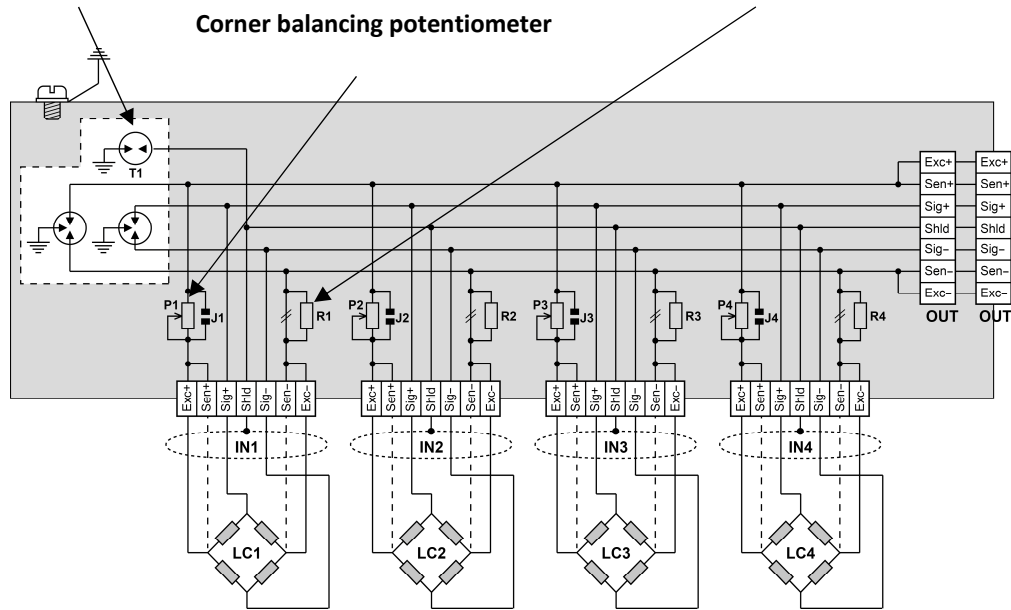

* cut strip conductor before insertion

4.6.1 Specifications

	Version Standard	Version ATEX / IECEx
Cable diameter (output)	Ø 6 ... Ø 11.5 mm	Ø 6 ... Ø 10 mm
Cable diameter (inputs)	Ø 2.5 ... Ø 7 mm	Ø 4 ... Ø 8 mm
Wire cross section	0.14 mm ² ... 1 mm ²	
Cable stripping length	7 ... 10 mm	

4.6.2 Excitation trimming procedure

For load cells with matched outputs, shortcut the potentiometers by soldering bridges J1, J2, J3, J4. First adjustment with reference weight:

1. Turn the potentiometers fully clockwise for each load cell so that the potentiometer resistance is as low as possible.
2. Lay your reference weight at one corner of your weighing system and note the result of the weighing indicator.
Repeat this operation for each corner.
3. Spot the corner with the lowest output.
Load successively each corner with the same reference weight and adjust at each step the potentiometer to match the lowest output corner value.
4. The load cells outputs are now matched.
Then proceed to normal zero and gain adjustment of the weighing indicator.

4.6.3 Spring terminal connections

Use a screwdriver with a maximum blade width of 3 mm.

1. Press the black button with the screwdriver.
2. Stick the wire end into the relevant opening.
3. Release the pressure on the screwdriver.
4. Pull slightly the cable to check it is held tight.

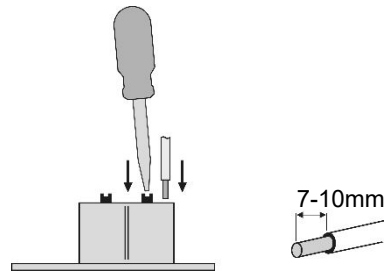

4.7 220V option

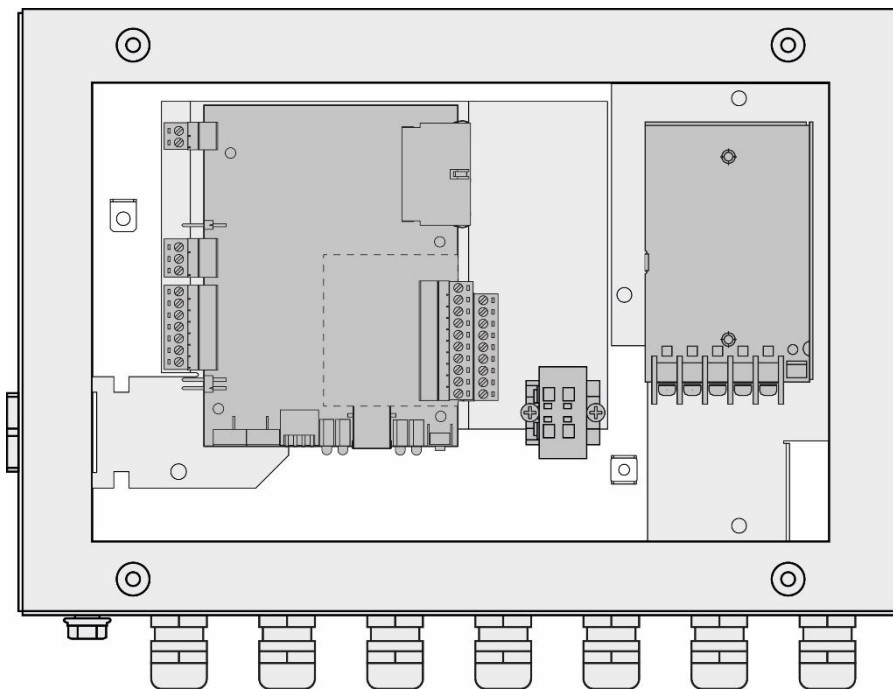

Plug the supplied power cord into the AC outlet.

5 COMMUNICATION

5.1 Communication Interface connections

5.1.1 Process control communication

Version	Type of communication	Connector
<i>eNod4 Modbus TCP</i>	<i>Modbus TCP</i>	<i>A7</i>
<i>eNod4 EtherNet/IP</i>	<i>EtherNet/IP</i>	<i>A7</i>
<i>eNod4 Profinet IO</i>	<i>Profinet IO</i>	<i>A7</i>
<i>eNod4 EtherCAT</i>	<i>EtherCAT</i>	<i>A7</i>

5.1.2 PC communication

eNod4 models can communicate with a PC using the protocols *Modbus RTU* or *SCMBus* through the *USB* connector accessible from the front panel.



USB Communication stops AUX communication when used.

The appropriate *USB* driver can be downloaded from our website: www.scaime.com. It is also available on CD to order from our sales department.

Note: If *eNodView* software has been correctly installed, it is not mandatory to re-install the *USB* drivers when connecting another *eNod4* on the same *USB* port (Windows only asks for the driver if the device is connected to another *USB* port).

5.1.3 AUX Communication (for HMI)

GND (connector pin3) is connected with power supply GND. The common mode voltage admitted is $\pm 27\text{VDC}$ from GND power supply. When *eNod4* is at the end of a bus line the $150\ \Omega$ integrated resistor can be used (connecting jumper).

Warning: Do not add termination line jumper on both side if distances between 2 devices is short.

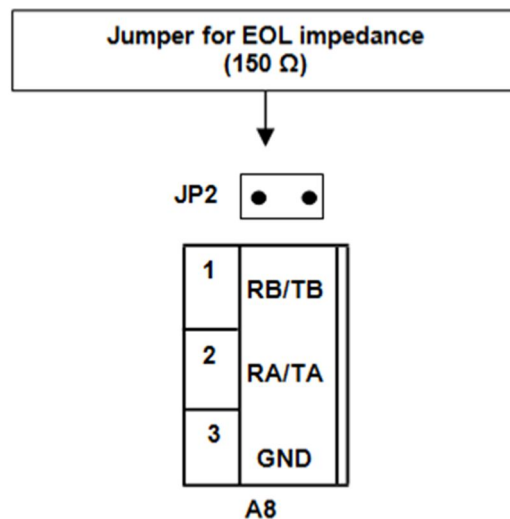

5.2 Communication address selection

Rotary switches selection (SW1 and SW2) accessible from the front panel. **The new address only is taken into account after a reset.**

Example: *eNod4* address = 3AH = 58d

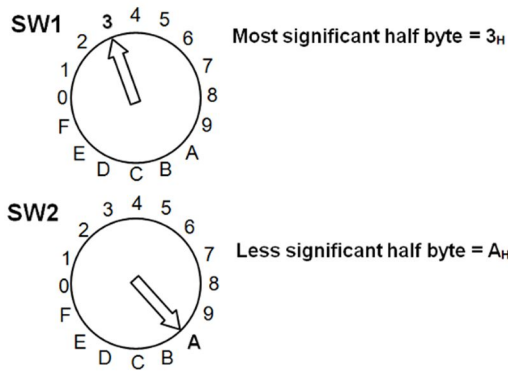

5.3 Communication rate selection

Dipswitch selection (SW3) is accessible from the front panel. The new baud rate only is taken into account after a reset.

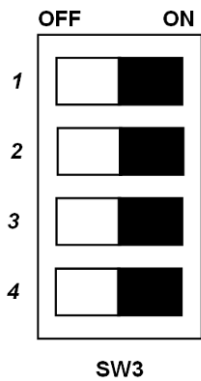

Dipswitch				Baud rate RS485 et USB	Bit rate CAN
1	2	3	4		
ON	ON	ON	X	9600	50 kbit/s
OFF	ON	ON	X	19200	50 kbit/s
ON	OFF	ON	X	38400	50 kbit/s
OFF	OFF	ON	X	57600	125 kbit/s
ON	ON	OFF	X	115200	250 kbit/s
OFF	ON	OFF	X	9600	500 kbit/s
ON	OFF	OFF	X	9600	1 Mbit/s
OFF	OFF	OFF	X	9600	125 kbit/s

5.4 Communication protocols

Model	Communication interface	Protocols*	Connector	Front panel LED
eNod4 Ethernet	RS485 AUX	ModBus RTU SCMbus	A8	/
	USB	ModBus RTU SCMbus	Front panel USB A4	Led USB USB Led
	Ethernet	Modbus TCP EtherNet/IP EtherCAT Profinet	A7	MS état du module MS Module Status NS état du réseau NS Network Status MS défaut système (vert) / défaut bus (rouge) MS system failure (green) / bus failure (red) NS état du réseau NS Network Status

5.5 Simultaneous functioning of communications

- DIN version

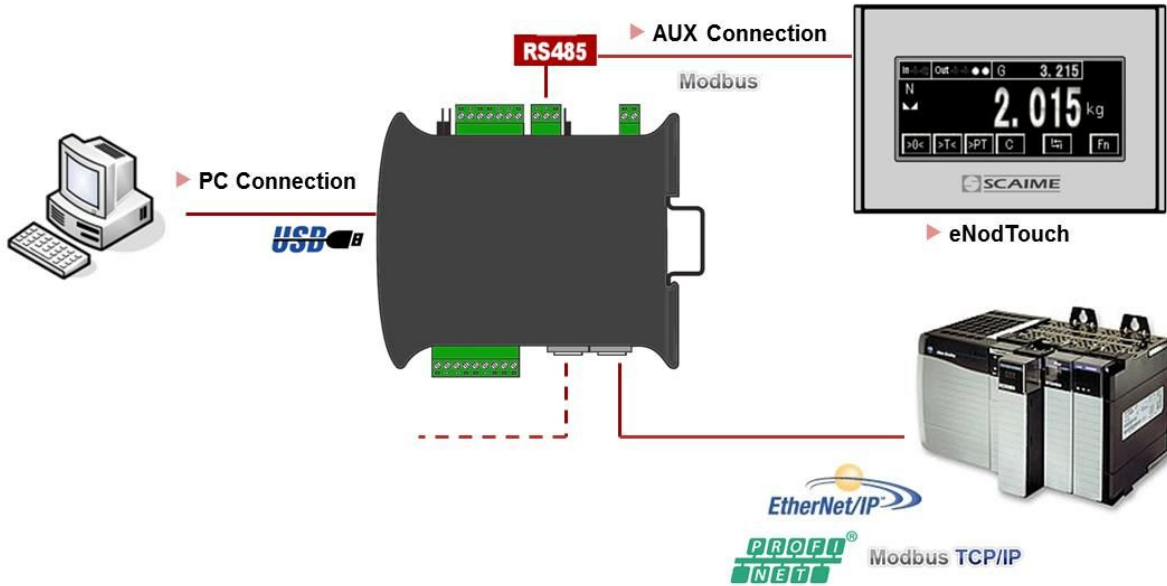

- Box version

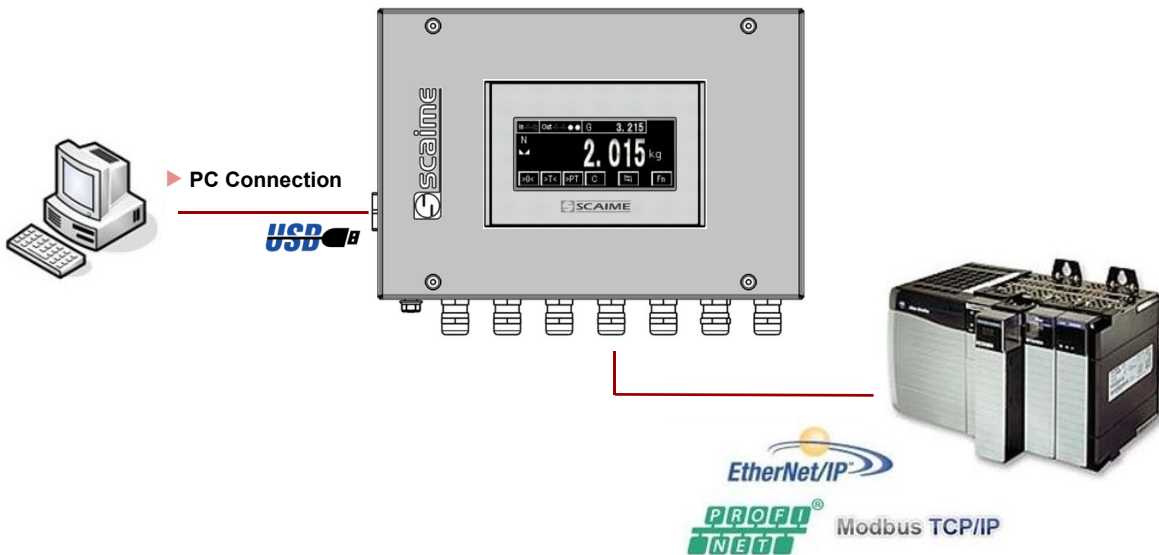

Simultaneous communication	Ethernet	RS485 AUX
USB	yes*	No
Ethernet		Yes**

(*) Simultaneous use of Ethernet with USB port can reduce performance of this interface.

(**) In this configuration, we recommend low speed rate on AUX output.

5.6 Bluetooth® Communication (Optional)

Information related to the radio emission are the followings:

Information Radio	
Wireless communication	Bluetooth® Low Energy 4.2
Max. RF output power	-16.9 dBm
Frequencies range	2.4 – 2.4835 GHz

Activation or deactivation of Bluetooth® fonctionnality is done by dipswitch #4 on SW3.

OFF		ON		Dipswitch				Bluetooth®
1	2	3	4	1	2	3	4	
				X	X	X	ON	Active
				X	X	X	OFF	Inactive

SW3

A blue light on front side indicates the status of the Bluetooth® communication.

Blue light	Bluetooth® COM Status
Off	Inactive
Fast blinking	Initialization
Slow blinking	Ready for pairing with mobile device
Steady On	Active and paired

The communication through Bluetooth® allows, using the dedicated mobile app **eNodApp**, to visualize the different weighing values, the Inputs / Output states and the applicative cycle states from an Android device. Moreover, it allows to perform some actions such as:

- Perform a Zero or Tare,
- Calibrate a sensor,
- Parametrize Inputs/Outputs,
- Set filtering parameters,
- Read/Clear DSD records,
- Set application parameters,
- And more...

The theoretical range of the Bluetooth® communication is about 10 meters without obstacles.

eNodApp application is available in English and French version and can be downloaded from the [Google Play Store](#).

6 CALIBRATION AND SCALE ADJUSTMENT

eNod4 is factory calibrated to deliver **500 000 counts for 2mV/V** with a load cell on the **A3** input connector. Initial calibration can be modified for a better adjustment to the usage or because of characteristics of the sensor. To achieve these various types of adjustments the following options and procedures are available:

- physical calibration
- theoretical calibration
- scale adjustment coefficient
- gravity correction



When using eNod4 for legal for trade purpose, it is imperatively required to activate the legal for trade switch BEFORE any calibration procedure (cf § legal for trade switch).

6.1 Physical calibration

Physical calibration is done by applying to the sensor **from 1 up to 3 known references**.

6.2 Theoretical calibration

The theoretical calibration allows defining **eNod4** user span **without using calibration reference**. The information needed to achieve the procedure is **the sensor sensitivity and its rated capacity**.

For example, a 15kg load cell with sensitivity equal to 1.870 mV/V at 15kg; put sensor maximum capacity 15 000 and sensor sensitivity 1,870.

6.3 Scale adjustment coefficient

Initial calibration value can be modified with a scale adjustment coefficient. This coefficient has maximum and minimum values.

6.4 Gravity correction

When **eNod4** is used to condition a weighing sensor, it can be necessary to adjust measurement if the place of measurement is different from the place where **eNod4** was calibrated. **eNod4** automatically adapts its span by storing into its non-volatile memory these 2 parameters: 'Calibration place g value' and 'Place of use g value'. Initial values for these coefficients are identical; they correspond to the g value of a calibration place located in ANNEMASSE FRANCE.

6.5 Scale interval

The scale interval is the difference between 2 consecutives indications. Possible values are: 1, 2, 5, 10, 20, 50, and 100. Modification of scale interval is taking into account after a new calibration.

7 FILTERS

There are four available filtering levels which can be associated:

- Filtering **related to the A/D conversion rate** including rejection of the mains frequency (50 or 60 Hz) harmonics.
- Low-pass Bessel filter
- Notch filter
- Moving average filter

7.1 Filtering related to the A/D conversion rate

The signal resolution is related to the conversion rate. The conversion rate might be chosen as low as possible, particularly for static applications. For dynamic applications, a compromise must be found between the measurement rate and the low-pass filter cut-off frequency. The **eNodView** software can be used to determine appropriate filter values. Choose a measurement rate that rejects the mains frequency harmonics according to the place of use, 50 or 60Hz.

7.2 Bessel low pass filter

A low-pass digital filter can be applied as an output of the A/D converter. The filter orders (available values are 2 or 3) and cut-off frequency are adjustable. **eNodView** software can be used to determine appropriate filter values.

7.3 Notch filter

A notch filter might be applied as an output of the low-pass filter (if used) or the A/D converter. It allows attenuating the frequencies within a band defined by high and low cut-off frequencies. The **eNodView** software can be used to determine appropriate filter values.

7.4 Moving average filter

This filter can be set in cascade after the previous filters. The Moving average filter is used to smooth the weight value in case of random interferences. This sliding average computes the mean of the 'n' last measures from the results of the previous activated filters. A high filter depth gives a better stability, with a longer response time.

8 MEASUREMENT AND STATUS

The **eNod4** transmits measure after signal and data processing through different protocols available. The accessible variables are:

8.1 Gross measurement

The '*gross measurement*' stands for the digital value after measurement scaling. It is affected by all the '*zero*' functions (power-up zero, zero tracking and zero requests). Zero request value can be saved in non-volatile memory (option).

8.2 Net measurement

The '*net measurement*' stands for the digital value after measurement scaling and tare subtraction.

8.3 Tare value

The '*tare value*' stores the calibrated value that is subtracted from the '*gross measurement*' so as to give the '*net measurement*'. This value can be saved in non-volatile memory (option).

8.4 Factory calibrated points

The '*factory calibrated points*' contains the measurement value without the user calibration layer. It is directly linked to the analog input voltage.

8.5 Logical IN/OUT level

The '*logical IN/OUT level*' allows reading any time **eNod4** logical inputs and outputs level.

8.6 Preset Tare value

A previous calculated tare can be restored using this variable. This value can be saved in non-volatile memory (option).

8.7 Measurement status

The measurement status contains information on eNod4 measurement parameters.

8.8 Weighing diagnosis

8.8.1 Global weighing diagnosis

An internal alarm flag reflects the integrity of the whole measurement chain. It's used to set logical output active or optional analog output in an error mode in order to warn about any deflection on the measurement chain (defective measurement).

This variable is set active when at least one of the followings conditions occurs:

- sensor input control result out of tolerances
- sensor input control command in progress
- sensor input control command failed (timeout)
- sensor input reference command in progress
- gross meas. < (- max capacity)
- gross meas. > (max capacity)
- analog signal out of the A/D converter input range
- EEPROM failure

This internal alarm flag is featured with adjustable specific de-bounced time and minimal activation time.

8.8.2 Sensor input control

eNod4 features a weighing diagnosis system allowing to check the integrity of analog sensor input by electrically simulating a load, resulting to a simulated weight value. This diagnostic system can be used together with the others defects detection systems in order to achieve overall integrity check of the measurement chain. This system involves two phases initiated by the user:

- The first, just after user calibration, allows taking a simulated reference weight value when the measuring chain integrity is OK.
- The second, when the user wants to check the integrity of the system, allows to make the difference between a new simulated weight value and the reference. Then this difference can be compared with a dedicated maximum tolerance value.

9 INPUTS FUNCTIONING

Each input can work individually in positive or negative logic. A holding time (de-bounced time) attached to all inputs can be configured.

9.1 Inputs assignment:

Function	Operating mode		
	transmitter	Belt scale	Belt weigh feeder
<i>none</i>	•	•	•
<i>tare</i>	•	•	•
<i>cancel tare</i>	•	•	•
<i>zero</i>	•	•	•
<i>transmit measurement</i>	•		
<i>measurement window</i>	•		
<i>dynamic zero</i>		•	•
<i>Start/Stop</i>		•	•
<i>Belt running detection</i>		•	•
<i>Clear totalization and errors counter</i>		•	•
<i>Sensor input control</i>	•	•	•
<i>Belt fault</i>		•	•

9.2 General functions

9.2.1 None

Inputs have no effect.

9.2.2 Tare

One or the other or both inputs can be assigned to the tare function. The tare acquisition is conditioned by a stability criterion that can be changed or inhibited.

Depending on the chosen logic (positive or negative), the tare is triggered by a rising or a falling edge.

9.2.3 Cancel tare

Depending on the chosen logic (positive or negative), the current stored tare value is erased by a rising or a falling edge.

9.2.4 Zero

One or the other or both inputs can be assigned to the zero function.

A new volatile zero value is acquired only if its value is within $\pm 10\%$ range of the specified capacity for a usage out of legal for trade and $\pm 2\%$ for legal for trade application. The zero acquisition is conditioned by a stability criterion that can be changed or inhibited.

Depending on the chosen logic (positive or negative), the zero is triggered by a rising or a falling edge.

9.2.5 Transmit measurement

This is only possible using standard or fast SCMBus format or CANopen® protocols.

The request can apply to:

- gross measurement.

- net measurement.
- factory calibrated measurements

A single measurement is transmitted per rising or falling edge (depending on the configured logic) on the input signal.

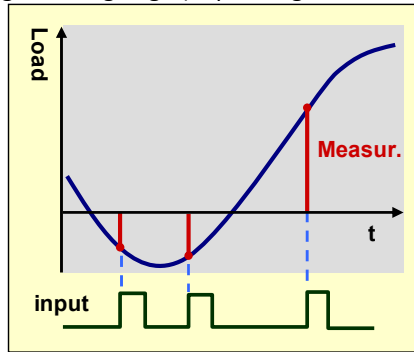

Fig. 7

9.2.6 Measurement window

This is only possible using *standard or fast SCMBus*.

The request can apply to:

- Gross measurement.
- Net measurement.
- Factory calibrated measurements.

While the input is kept at the right level, a series of measurements are transmitted at the period defined by the 'sampling period' setting. Only input 2 is operational if both inputs are assigned to

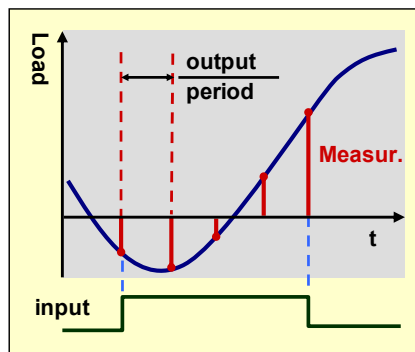

Fig. 8

9.2.7 Sensor input control

The assignment of logical input to sensor input control function allows performing special procedure to diagnose load cell sensor input. Beforehand, user must acquire reference value of the load cell input by sending 'Sensor input control reference' specific command (e.g. after the device is calibrated).

Note: Load cell sensor input control must be realized if no process cycle is in progress.

9.3 Functions attached to an operating mode:

See corresponding sections for a complete description.

10 OUTPUTS FUNCTIONING

Each output can work individually in its own logic.

10.1 Outputs assignment:

Outputs individually might be assigned to following functions:

<i>function</i>	<i>Operating mode</i>		
	<i>transmitter</i>	<i>Belt scale</i>	<i>Belt weigh feeder</i>
<i>none</i>	•	•	•
<i>set point</i>	•	•	•
<i>motion</i>	•	•	•
<i>defective measurement</i>	•	•	•
<i>input image</i>	•	•	•
<i>level on request</i>	•	•	•
<i>belt alarms</i>		•	•
<i>external totalizer</i>		•	•
<i>belt system running</i>		•	•
<i>batch in progress</i>		•	•
<i>batch result available</i>		•	•
<i>conveyor starting alarm</i>		•	•
<i>material TOR gate</i>		•	•
<i>motor activated</i>		•	•

10.2 General functions:

10.2.1 None:

The output has no function

10.2.2 Set point:

The outputs can be assigned to configurable set points (cf. §8) Output 1 is assigned to set point 1, output 2 to set point 2, output 3 to set point 3 and output 4 to set point 4.

Set points are characterized by a high and a low value.

Their operating mode is either *operating in hysteresis* or *operating in window*.

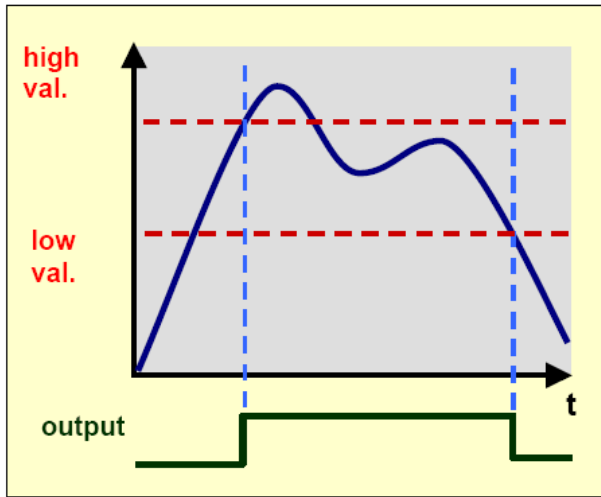

Functioning in hysteresis
Fig. 2

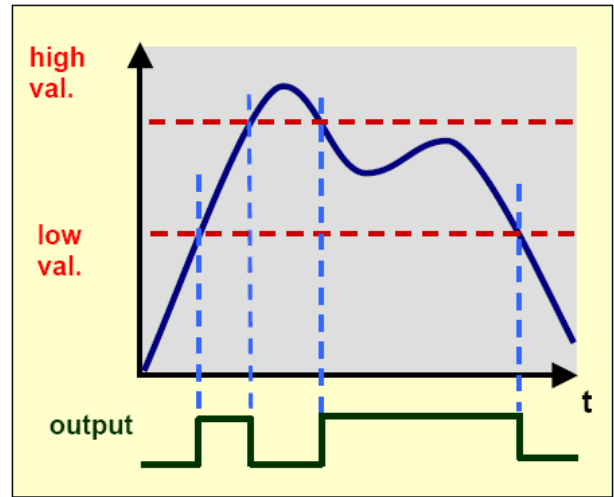

Functioning in window
Fig. 3

The low and high values of these set points may be assigned either to (regardless of the operating mode):

- gross measurement
- net measurement
- Sensor input control result
- Batch

10.2.3 Motion:

The outputs can be assigned to copying measurements stability.

10.2.4 Defective measurement:

The output level is set when the internal alarm flag described in “Weighing diagnosis” § in the MEASUREMENT AND STATUS § is activated. This allows to warn about defection of the measurement chain. Flowrate alarms are not considered as defective measurements.

10.2.5 Input image:

Outputs can be assigned to copying inputs state, either using the same logic or inverting the input state (negative logic). Outputs 1 and 3 are assigned to input 1&3 and outputs 2 and 4 are assigned to input 2&4.

10.2.6 Level on request:

The input level is driven by master requests.

10.3 Functions attached to an operating mode:

See corresponding sections for a complete description.

10.4 Optional analog output (IO+ version)

An optional analog board in *current* and *voltage* might be used with **eNod4** to provide IO+ version. This must be asked when ordering **eNod4** product.

Voltage output might be set either 0-5V or 0-10V, and the current output to 4-20mA, 0-24mA, 0-20mA or 4-20mA with alarm at 3.6mA. Both output (current and voltage) might separately be enable. Settings are effective after **eNod4** reset.

Analog output affectation function is common to both *current* and *voltage* output and might be assigned to followings:

<i>function</i>	<i>Operating mode</i>		
	<i>transmitter</i>	<i>Belt scale</i>	<i>Belt weigh feeder</i>
<i>none</i>	•	•	•
<i>gross measurement</i>	•	•	•
<i>net measurement</i>	•	•	•
<i>level on request</i>	•	•	•
<i>flow rate control output</i>		•	•
<i>instant flow rate</i>	•	•	•
<i>average flow rate</i>	•	•	•
<i>average belt speed</i>	•	•	•

If extraction command is directly done by an external device (e.g. PLC), through **eNod4** analog output, the output must be set on **level on request** function.

In **flow rate control output** mode, we can start and stop analog output with ramp-up and ramp-down. It's useful for controlling motor.

When analog output is assigned to "Gross measurement", "Net measurement", "Instant flow rate" or "Average flow rate" its value jumps to a special error value when the internal alarm flag described in "Weighing diagnosis" § in the MEASUREMENT AND STATUS § is activated. This allows to warn about defection of the measurement chain.

11 BELT WEIGHER OPERATING MODE

11.1 Introduction and Overview

eNod4 belt conveyor scale is a device that continuously measures bulk material as it moves along a conveyor. The system requires two general parameters to operate:

- It needs to know the weight of the material being moved along the conveyor belt
- It needs to know the speed at which it's moving along the conveyor belt.

The weight of the material on the belt is determined by weighing a section of conveyor belt loaded with material and then subtracting the average weight of the unloaded belt. The speed at which the material is moving is determined by measuring the speed of an idler or wheel in contact with the conveyor belt. The weight and speed is combined to produce a running total and a rate of flow of material going through the belt conveyor scale. The correct operation of the scale system requires the components to be installed correctly, periodically calibrated, and properly maintained.

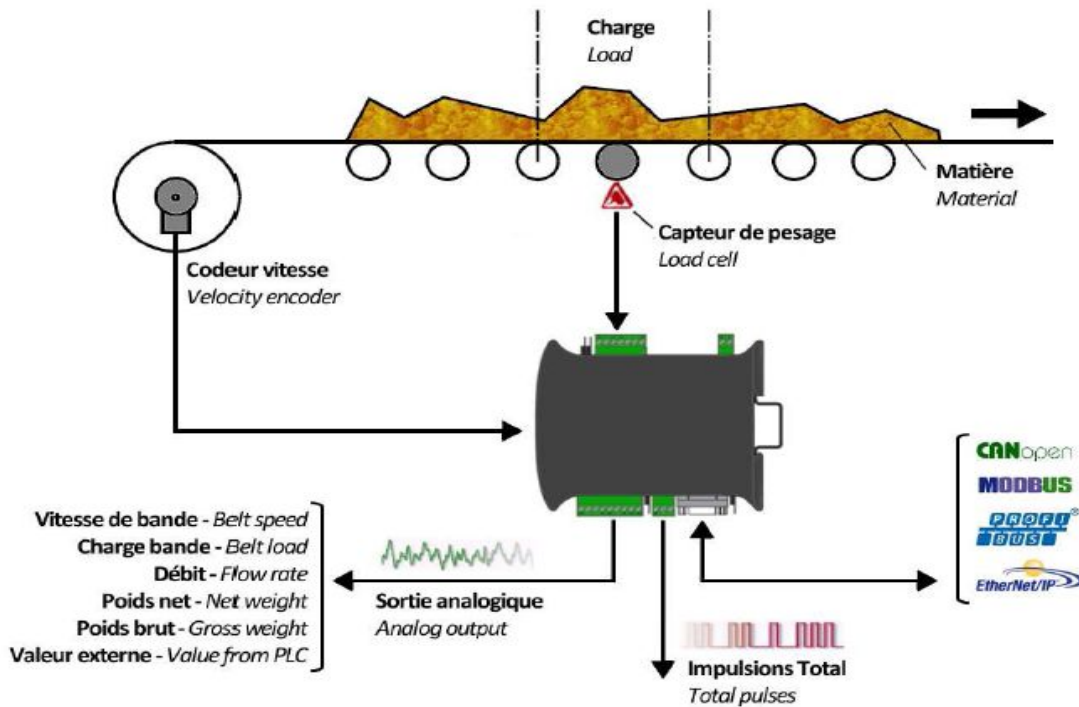

Belt scale operation

In **belt scale** operating mode, **eNod4** continuously calculates the total amount of material that goes through the weighing system and calculates the flow rate of material instantaneously.

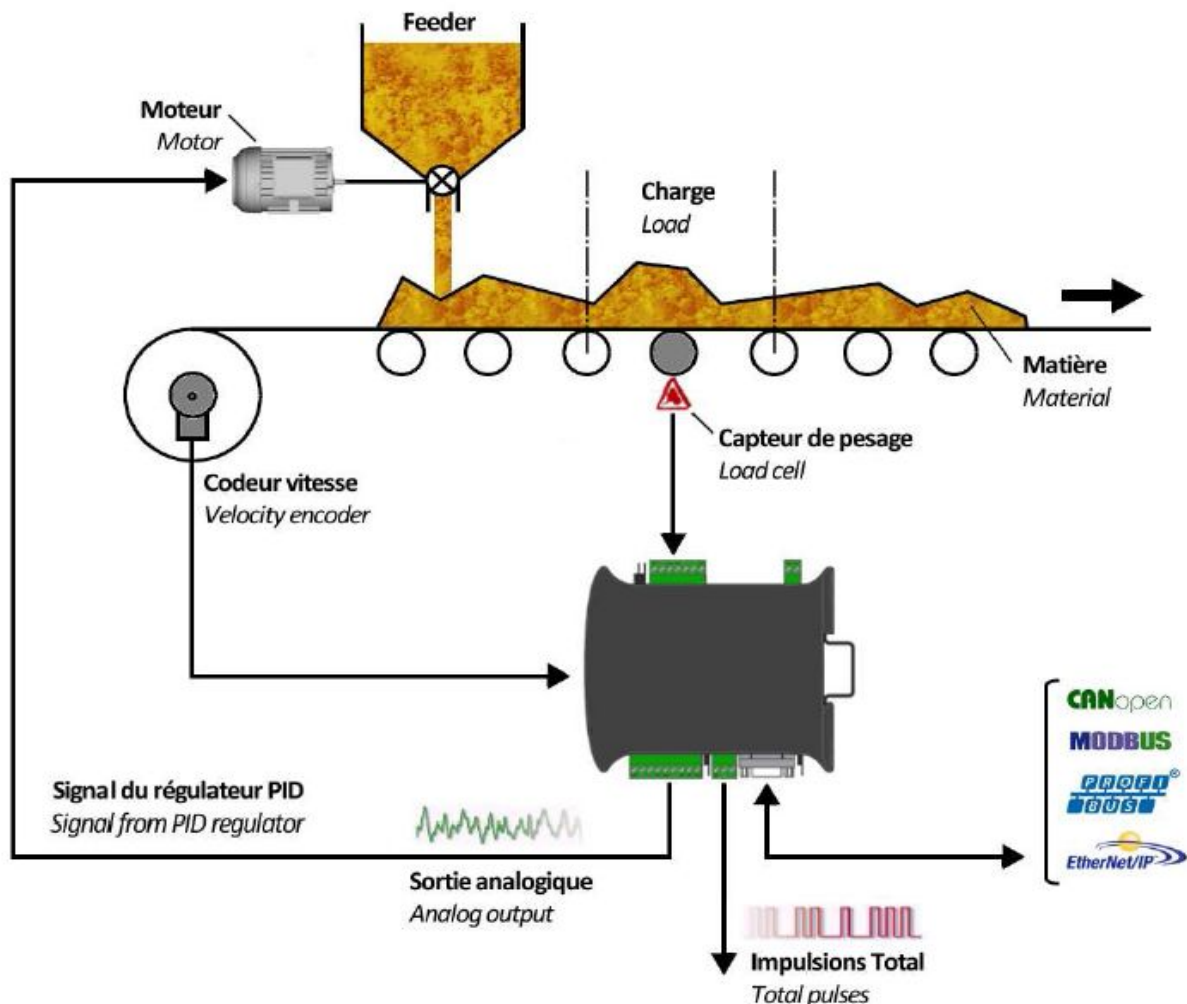

Belt weigh feeder operation

The **weigh feeder** is used to deliver an accurate mass flow rate of materials. In most applications, materials are provided by an adjustable mechanical shear gate, which fixes the correct material bed depth for a given particle size. The feed rate is then maintained adjusting the speed of the belt. However, in some cases the belt speed is constant with rate control done by a pre-feeding device.

The system consists of three components: weight and speed sensing, integration and control, and the mechanical conveying system.

Using the belt load and the belt speed signals, small incremental totals of weight per time are measured by **eNod4** which calculates the flow rate. The measured flowrate is compared to the set point flow rate and the on-board PID controller makes necessary corrections to the belt speed or materials feed.

11.2 Totalization cycle description

11.2.1 Cycle options

Cycle options define **eNod4** device functioning

- **Batch mode**

If batch mode option is activated, **eNod4** will automatically stop dosing when the total weight will have reached batch target values (Batch set point minus Inflight weight value), the scale material flow stops automatically.

The batch target value consists of two variables, the **main weight to totalize** in **weight unit** x 1000 and the **complementary weight to totalize** in **weight unit**.

Inflight weight value is expressed only in **weight unit**.

- **Clear totalization**

If **cleared totalization at starting of new cycle option** is activated, **eNod4** reinitializes total value. The main variable **weight to totalize** in **weight unit** x 1000 and the **complementary weight to totalize** in **weight unit** are reset to zero.

- **PID Activation**

It is possible to assign **eNod4** current or voltage analog output to extraction command (Setting to **flow rate control output**).

In **weight feeder** mode, when **PID activation** option is activated, **eNod4** will adjust the flow of extraction function to maintain constant flowrate regarding the flowrate set point. The measured flowrate is compared to the set point flow rate and the on-board PID controller makes necessary corrections to the belt speed or materials feed. The configuration of this plan of regulation can be made in a totally automatic way. We can stop and restart PID at any dosing cycle step. If we stop PID, the extraction command value is fixed to nominal. **So that this plan of regulation works, it is necessary to realize weight calibration indication and flow rate calibration beforehand.**

11.2.2 Weight section length (mm)

Effective weight section length is defined as length units in **millimeters (mm)**. The effective weight section length corresponds with half of the distance between the belt rollers which are found before and after the roller with the belt scale. The effective weight section length is calculated as follows:

For scale with one Idler

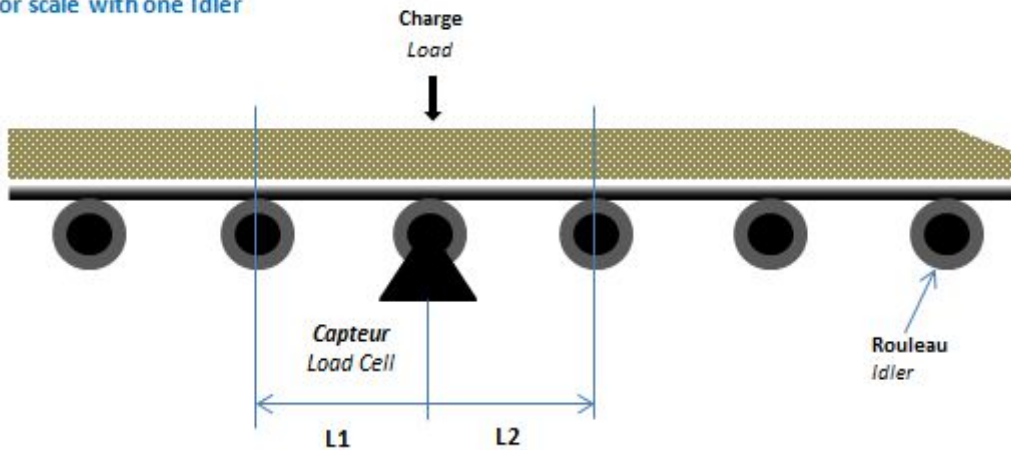

$$\text{Effective weight section length} = \frac{L1 + L2}{2}$$

For scales with two Idlers

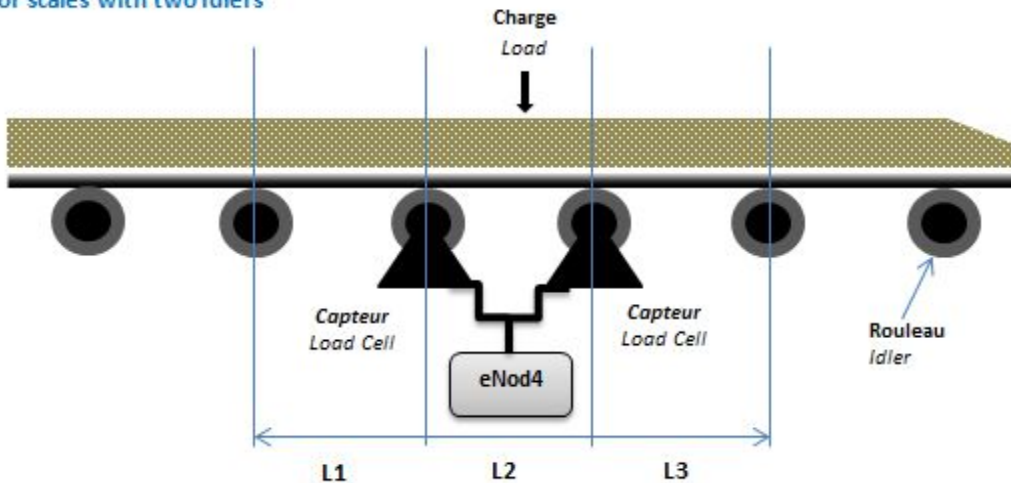

$$\text{Effective weight section length} = \frac{L1 + L3}{2} + L2$$

11.2.3 Conveyor inclination (degrees)

“Belt tilt angle” (angle of conveyor in degrees) allows correcting the effect of inclination on the weight. If the belt is mounted horizontally, the definition is 0. The belt can be tilted to a maximum of 35°. Always ensure that the definition corresponds with the current tilt angle, otherwise the belt load is incorrectly calculated.

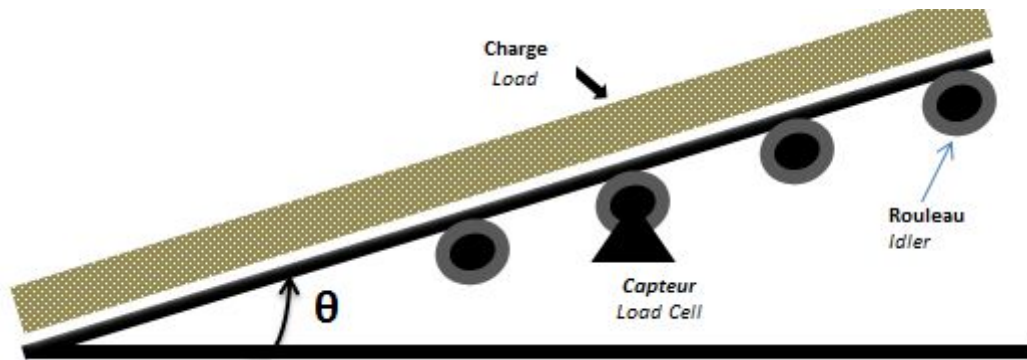

11.2.4 Minimum load to totalize (weight unit/meter)

Minimum load to totalize is the limit value for minimum belt loading in 0.01 % of totalization weight unit. The entry of the number e.g. 1000 corresponds to 10 weight unit. After this value has been exceeded **eNod4** sets the status bit “**min. totalize load targeted**” in status register and starts totalization function.

eNod4 determines the **Minimum load to totalize** by calculating:

$$\text{Minimum load to totalize} = \frac{\text{Minimum weight (in weight unit)}}{\text{Weight section length (in meter)}}$$

11.2.5 Pulses factor speed sensor (Pulses/meter)

The pulse constant of the speed sensor indicates the number of pulses per meter of the belt. **eNod4** calculates the current belt speed on this base. The value of pulses factor can be calculated by **eNod4** during a speed calibration.

11.2.6 Measurement time factor for speed (x250ms)

The belt speed is defined as output in meter per second (m/s). By default, **eNod4** device estimated speed determination every **250ms** (*time factor for speed is set to 1*). The measuring time factor of the pulse input can be set to another time e.g. 4 (for 2 seconds). The number of pulses from the speed sensor within this period is summed to estimate the belt speed. The **speed** value output is updated in this case every 2 seconds and the value is shown in **eNod4** as meter per second.

11.2.7 Constant belt speed (m/s)

Constant belt speed must be defined if no speed sensor is connected to **eNod4** device. The calculation of the flow-rate is then performed using this value.

When a speed sensor is connected to **eNod4**, constant belt speed must be set to 0.

11.2.8 Flow correction factor

Correction factor can be used to correct deviations in the total dosed amount by compensating for mechanical variations. When the final dosed amount is checked by weighing the resulting weight, **eNod4** can recalculate this factor by calculating:

$$\text{New Correction} = \text{Correction} \times \frac{\text{Checked Batch Total}}{\text{Current batch total}}$$

The next batch the **Batch Total** and **Checked Batch Total** should be close together.

11.3 Belt calibration

Initial calibrations must be performed on belt system to achieve correct display of process data. User has to do the following steps:

- 1) Speed sensor calibration (mandatory)
- 2) Static weight calibration (mandatory)
- 3) Material Test (Dynamic weight calibration or correction factor)

11.3.1 Speed sensor calibration

Speed calibration must be performed when the conveyor is running and empty. The following parameters are involved during speed calibration procedure:

- **Pulses factor speed sensor (Pulses/meter)**, user can get this data from speed sensor datasheet. Using this parameter, **eNod4** allows estimating the **conveyor total length**.

- **Conveyor total length**, if user does not know **pulses factor speed sensor (pulses/meter)**, he has to fill this parameter and **eNod4** allows estimating **pulses factor**. At end of calibration the current belt speed must match the real speed.
- **Number of revolutions**, for auto-calculation of **pulses factor** or **conveyor total length**, user must fill this parameter with correct value (effective number of revolutions to be realized during procedure). It is recommended to set and to achieve a maximum number of revolutions to improve result accuracy.

Procedure of auto-calculation (**pulses factor** or **total length**) is as following:

- Stop the conveyor and make sure it is empty
- Mark the belt (for reference point)
- Start the conveyor
- Send corresponding "**Init calibration**" command at marked point
- Count real number of belt revolutions handled
- Send corresponding "**End calibration**" command at marked point and when specified number of revolutions is done.
- Check and compare updated value of **pulses factor** or **conveyor total length**.

Note: See functional commands section about commands list.

11.3.2 Static weight calibration

Static weight calibration must be performed when the conveyor is in stop state. **eNod4** device allows several methods of static weight calibration. These methods and procedures are described in specific calibration and scale adjustment section. Refer to it for more details.

11.3.3 Material Test (Dynamic weight calibration or correction factor)

The Material Test can only be performed once a static weight calibration has been completed and once the belt speed sensor has been installed and calibrated.

The belt scale allows for two calibration methods. Static weight calibration is the easiest method and is a combination of test weights applied to each weigh idler, belt spacing and speed calibration. The second optional calibration method is a Material Test calibration in which a known amount of test material is fed on the moving belt scale. Then, user must check the amount of test material with a measurement instrument and apply a correction factor to make at next batch **eNod4** displayed total weight matches the test material weight.

11.4 Calibration of flow rate

So that **eNod4** can carry out an expected flow rate dosing in the best conditions possible, the flow rate output control calibration is required. This also applies when **eNod4** is used both as **belt scale** or **belt weigh feeder**.

From this calibration will depend the accuracy of the flow rate obtained and on the actuation time delay, if a PID regulator controls it. This calibration is carried out in minimum two segments by the variable **segments number for the calibration curve of flow rate**. In case the extraction device has a nonlinear response, it is recommended to define maximum segments for the flow rate calibration.

If the control of extraction device is directly provided by **eNod4** through a control analog output in **current** or **voltage**, the **current** or **voltage** analog output of **eNod4** must be allocated to "**level on request**" function.

For each calibration point of the variable **control output value**, read the appropriate average flow rate. Then provide each of the **Calibration of control output point n / analog output** and **Calibration of flow rate point n matching with control output value**. Validate the flow rate calibration by **calibration of flow rate** control.

Allocate in the end the **current** or **voltage** analog output of **eNod4** to "**flow rate control output**" function.

11.5 Totalization

eNod4 realizes totalization function continuously while belt loading is greater than **minimum load to totalize** even if no batch cycle is in progress.

The **totalization result** is composed of two parts, the main part in **weight unit x 1000** and the second one **complementary in weight unit**.

In **batch mode** and when **cleared totalization at starting new cycle** option is activated, this totalization result is set to zero at each cycle start.

There are two others levels of totalization expressed only in **weight unit x 1000** (**Great total** and **General total**).

Each totalization result can be independently set to zero. The data of these totalizers is being permanently backed up after modification.

If one of these 4 outputs is allocated to an external totalizer, a pulse is sent when the value totalized increases by a multiple value of the parameter **weight quantity per pulse on logical output**.

11.6 Alarms

Alarms are disabled when the corresponding control parameters are set to zero, otherwise they are activated. These alarms will not affect the functioning of **eNod4** device but only be displayed. They will continue to be displayed until the condition disappears. Once the condition is cleared, the alarm is cleared.

The following data process can be monitored:

- Instant flowrate
- Instant belt load
- Flowrate control output
- Instant belt speed
- External totalizer overflow
- Belt fault

11.6.1 Minimum flow rate limit value (0.1%)

Minimum flow rate is the limit value for flowrates in 0.1% of the **nominal flowrate**. The entry of the number e.g. 800 corresponds to 80.0%. When the instant flowrate on the belt is lower than this level, **eNod4** sets the alarms bit "<min. instant flowrate" in **belt alarms register**.

11.6.2 Maximum flow rate limit value (0.1%)

Maximum flowrate is the limit value for flowrates in 0.1% of the **nominal flowrate**. The entry of the number e.g. 1020 corresponds to 102.0%. When the instant flowrate on the belt is higher than this level, **eNod4** sets the alarms bit ">max. instant flowrate" in **belt alarms register**.

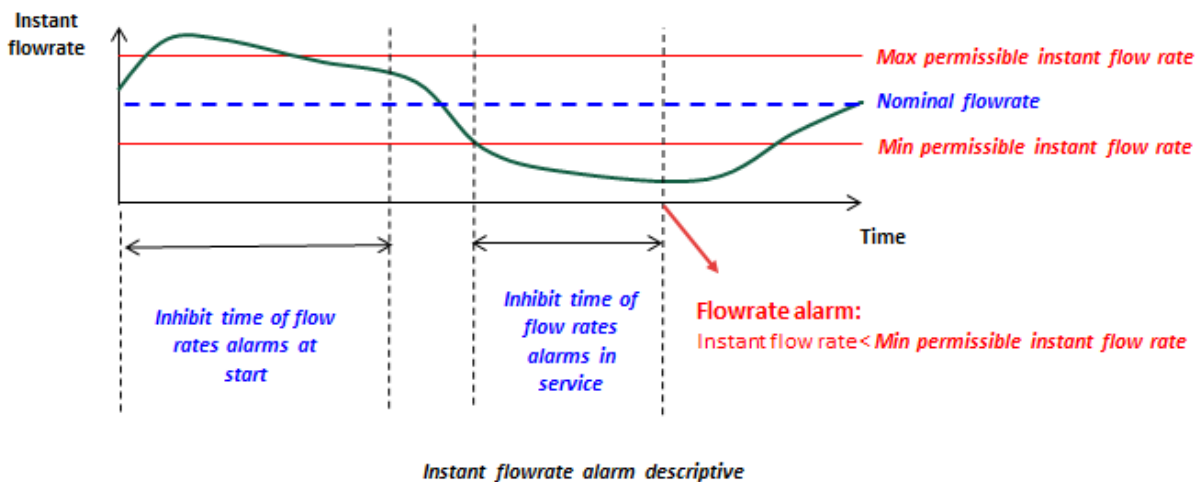

11.6.3 Minimum belt load limit value (0.1%)

Minimum belt load is the limit value for density weight in 0.1% of the **nominal load**. The entry of the number e.g. 800 corresponds to 80.0%. When the instant density weight on the belt is lower than this level, **eNod4** sets the alarms bit "<min. instant load" in **belt alarms register**.

11.6.4 Maximum belt load limit value (0.1%)

Maximum belt load is the limit value for density weight in 0.1% of the **nominal load**. The entry of the number e.g. 1020 corresponds to 102.0%. When the instant density weight on the belt is higher than this level, **eNod4** sets the alarms bit ">max. Instant load" in **belt alarms register**.

11.6.5 Minimum control output limit value (0.1%)

Minimum control output is the limit value for control output in 0.1% at **nominal flowrate**. The entry of the number e.g. 800 corresponds to 80.0%. When the control output on the belt is lower than this level, **eNod4** sets the alarms bit "<min. control output" in **belt alarms register**.

11.6.6 Maximum control output limit value (0.1%)

Maximum control output is the limit value for control output in 0.1% at **nominal flowrate**. The entry of the number e.g. 1020 corresponds to 102.0%. When the control output on the belt is higher than this level, **eNod4** sets the alarms bit ">max. control output" in **belt alarms register**.

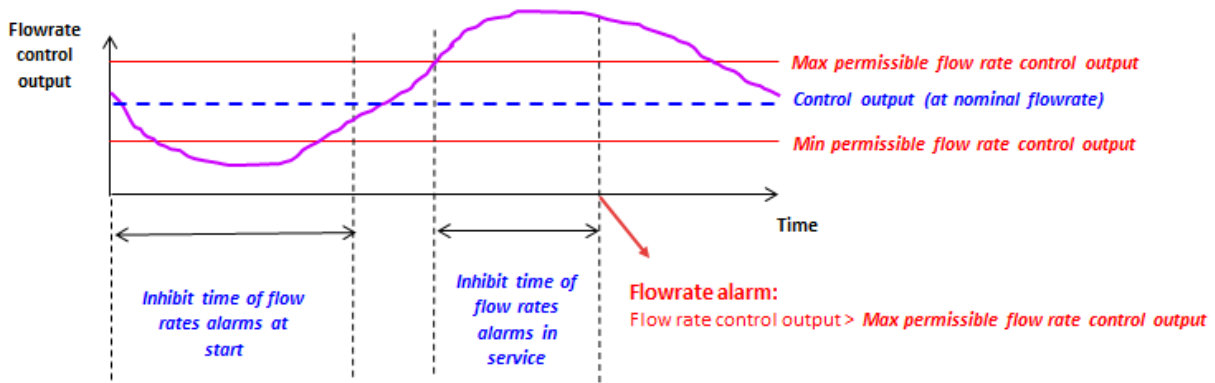

Flowrate control output alarm descriptive

11.6.7 Minimum belt speed limit value (0.1%)

Minimum belt speed is the limit value for minimum belt speed in 0.1% of the nominal speed. The entry of the number e.g. 800 corresponds to 80.0 %. After this value has been exceeded, **eNod4** sets the status bit “<min. speed” in **belt alarms register**.

11.6.8 Maximum belt speed limit value (0.1%)

Maximum belt speed is the limit value for maximum belt speed in 0.1% of the nominal speed. The entry of the number e.g. 1020 corresponds to 102.0%. After this value has been exceeded, **eNod4** sets the status bit “>max. speed” in **belt alarms register**.

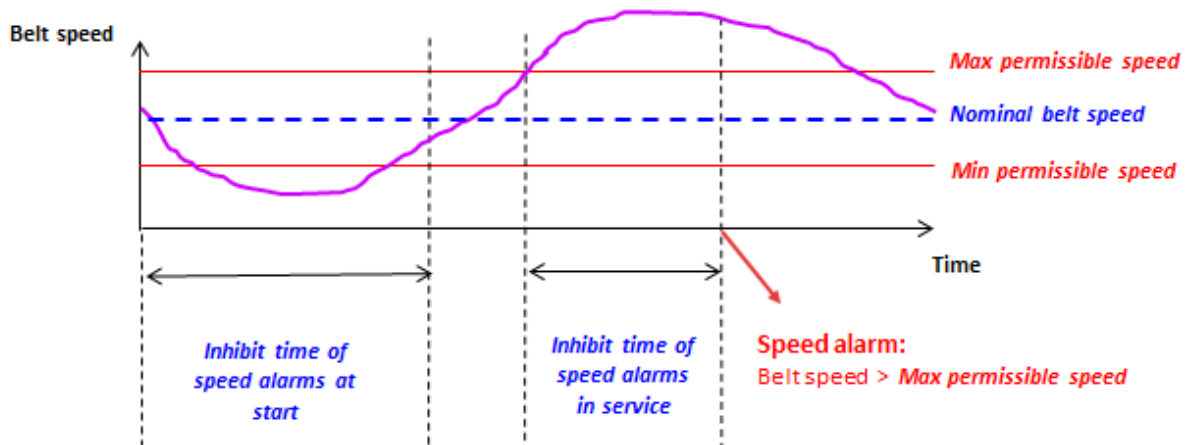

Belt speed alarm descriptive

11.6.9 Inhibit time of speed alarms at start (ms)

Monitoring the belt speed is only activated after this delay time when the belt is started.

11.6.10 Inhibit time of speed alarms in service (ms)

When the belt speed is below/above the min/max belt speed, the alarm is activated after this delay elapsed.

11.6.11 Errors counter

Any alarm disappears automatically when the origin of the defect disappears. In every emitted alarm, the variable **error counter** is incremented.

Error counter variable can only be set to zero using **clear dosing/batch** command.

11.7 Inputs assignments

eNod4 device could have up to **5 Inputs** (with **IO+ option**). One of them is especially reserved for **speed sensor** input. All others logical inputs can be assigned to functional dosing process commands. All process commands have edge functioning.

- **Start / Stop dosing (and batch)**

If starting conditions are fulfilled, a rising or a falling edge (according to the configured logic) on this input causes a new totalization cycle to start.

In **batch mode** and when **cleared totalization at starting new cycle** option is enabled, the totalization result is set to zero at each cycle start.

If dosing cycle is running, a second edge of this command stops the process.

- **Belt running motion detection**

If speed sensor is broken or if no speed sensor is connected to **eNod4** device, a logical input on the **eNod4** can be assigned to **motion detection** function to enable totalization function.

- **Clear/Reset totalization and errors counter**

Clear totalization function can be assigned to logical input. You can clear total amount dosed and errors counter at any time. At this input activation on rising or falling edge (according to the configured logic), the **main total** in **weight unit x1000** and the **complementary weight** value are reset to zero.

Also, **errors counter** parameter is set to zero.

- **Dynamic zero**

When the belt is running empty, this input activation will cause **eNod4** to perform conveyor zero function by measuring flow rate of materials.

Run the conveyor for several minutes to ensure the belt is empty and supply. The conveyor should be operating at **normal speed** throughout the calibration. Dynamic zero function duration will depend on the **number of revolutions** chosen, the belt length and the speed. The procedure will complete its cycles unless an **exit calibration** command is sent.

- **Belt Fault**

Belt Fault function should be assigned to logical input. At this input activation on rising or falling edge (according to the configured logic), **Belt fault alarm** is activated.

12 ENODTOUCH – HUMAN MACHINE INTERFACE (OPTION)

12.1 Online functioning

12.1.1 Startup screens

- At first Power-On, eNodTouch is set to manage one eNod4 at the address 1, the connection screen is displayed while eNodTouch try to communicate with connected eNod4 device.
- Then a redirection screen appears during 3 seconds for a redirection to a main screen if the communication is established between eNodTouch and eNod4 communication or an error screen if eNodTouch does not manage to connect to the eNod.
- If there is no eNod4 connected or if the display unit cannot communicate with eNod4 device, a communication error screen appears. In this case, check the wiring between eNodTouch and eNod4 (§ *Electrical Powering*) and check that the communication parameters of eNodTouch and eNod4 are correct (§ *Peripheral – Device PLC Settings*).



Connection screen



Communication error screen

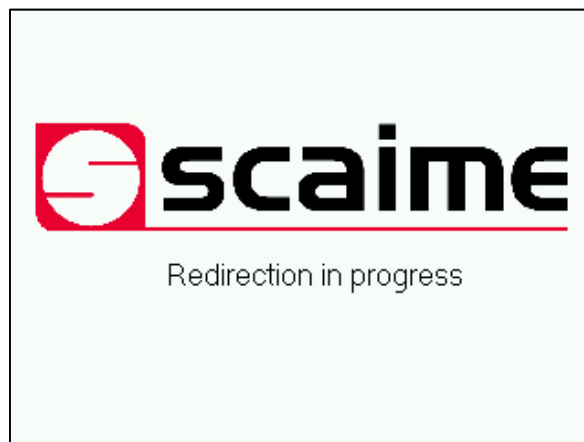

Redirection screen

- When communication is established the main screen of eNod4 appears:

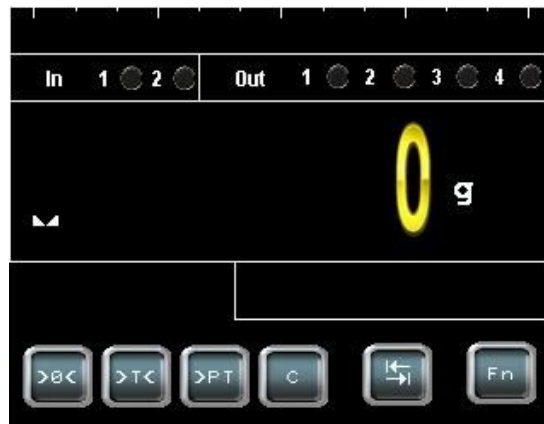

12.1.2 Multi-eNod screens

12.1.2.1 Increase eNod number

- To increase the eNod number and have an access to the multi-eNod screen, please follow the procedure:
 - Touch the Fn button of the main screen, the main menu appears.
 - Enter in the eNodTouch menu.
 - Go to the Starting Parameters screen by touching the right arrow button.

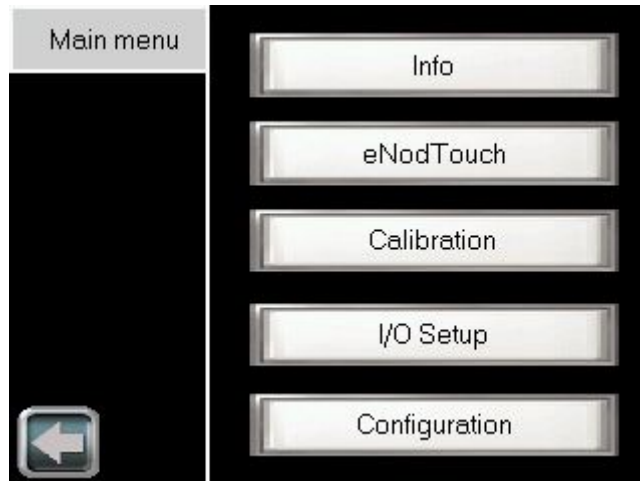

Main Menu

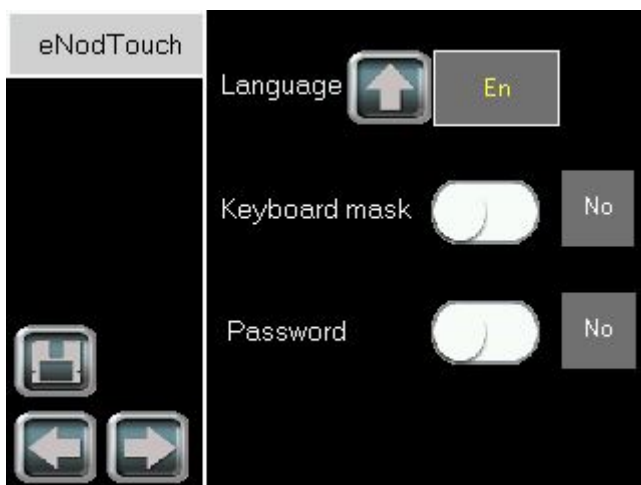

eNodTouch menu

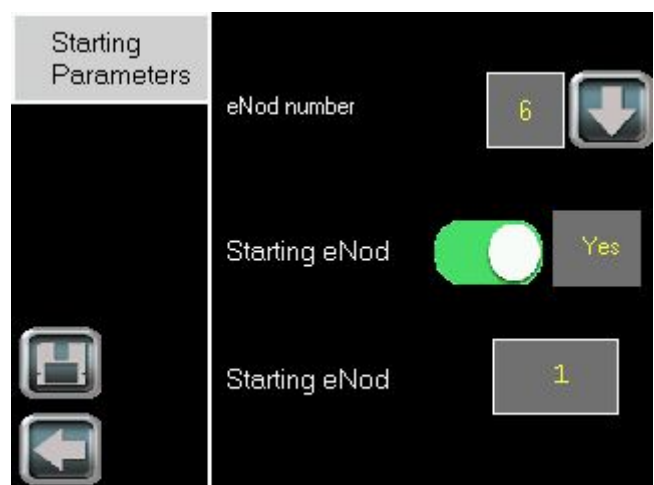

Starting parameters

- By default the eNod number is 1, eNodTouch starts on the main screen of the first eNod.

- Increase eNod number if needed. The display module can start on the main screen of any eNod or on the multi-eNod screen by disabling « Starting eNod » function.
- If starting eNod is disconnected or have communication problems, the multi-eNod screen appears.
- When settings are finished, touch the left arrow button, to restart eNod Touch.
- According to the number of eNod settled, eNodTouch redirects to the following multi-eNod screens:

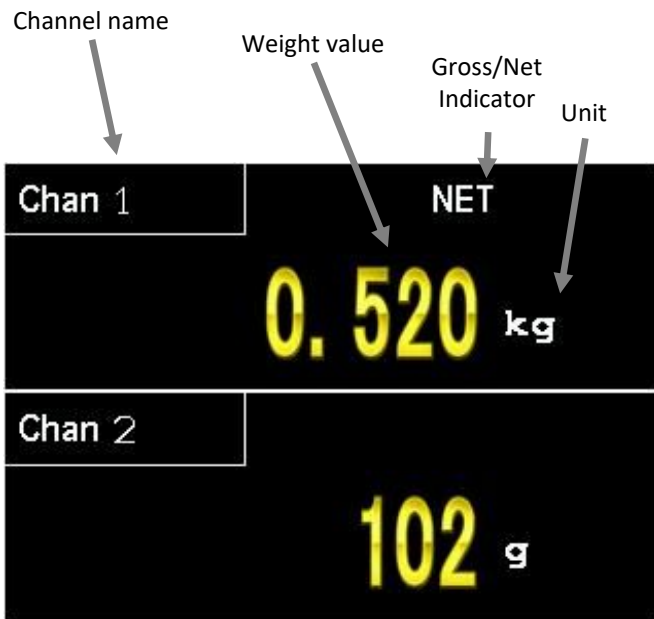

Multi eNod (2 eNod)



Multi eNod (3 eNod)



Multi eNod (4 eNod)



Multi eNod (5 eNod)



12.1.2.2 Select an eNod



Touch its display area

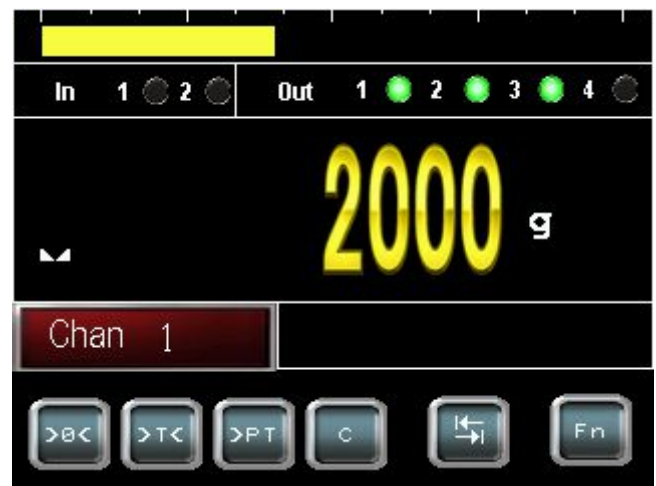

Main screen of eNod

- To display the main screen of an eNod, touch its display area (Example for eNod n°1):
- To return to multi eNod screen, touch the channel red button:

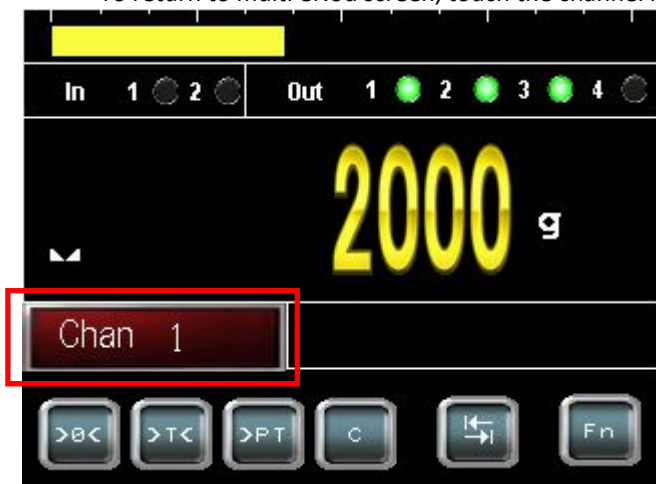

Touch of channel display

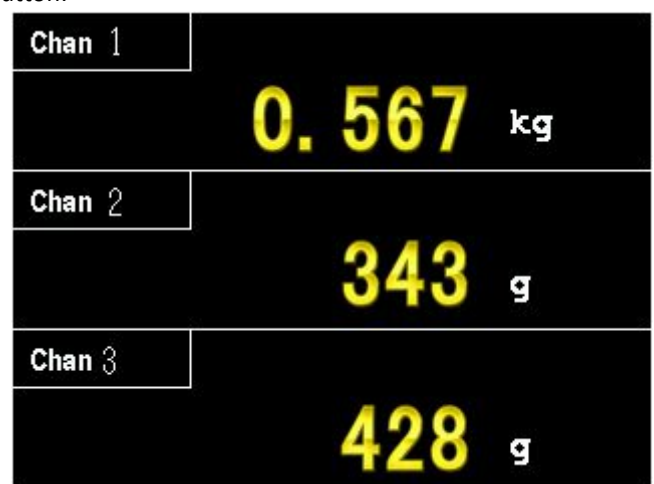

Multi-eNod screen

12.1.2.3 Communication error and disconnection

- When an eNod4 has communication problems or is disconnected, the data from other channels freezes for 5 seconds. During this time, a reconnection button appears, eNodTouch tries to recover the connection with eNod4.



- After 5 seconds if eNodTouch can not recover the connection with eNod4, the button enters in the state « eNod disconnected », the data display resumes.





- Identify the communication problem in the following list: wiring problem (§1.4), communication parameters misconfigured on eNodTouch or eNod4 (§2.2.3).
- When you found out the issue, touch the « eNod disconnected » button to re-establish the communication.
- The display module tries to recover the communication with eNod4 during 1 second, the button toggles to the « Reconnection » state. After 1 second if data from the eNod4 appears, the communication is re-established, else the button toggles to « eNod disconnected » state.

12.1.3 Main screen

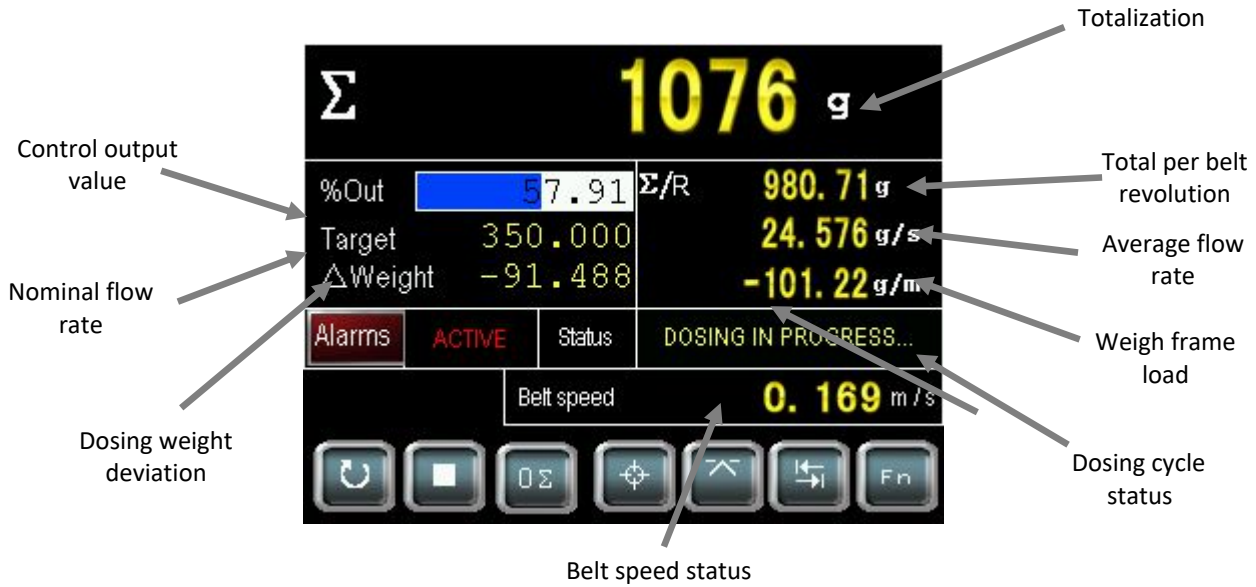
12.1.3.1 Dosing Mode (eNod4-B)



Second Keyboard









- To switch from the main keyboard to the 2nd keyboard touch 
- To enter the dosing quick access menu touch 
- To enter the Dosing error menu touch 
- To switch between “Totalization” and “Average flow rate” (e.g.: for flow rate calibration) touch













- For a quick access to analog output control (e.g.: for flow rate calibration) only when analog output is set to “Remote access” function touch





12.1.3.2 Keyboard functions

eNod4 model	Key	Action
Main Keyboard and 2nd Keyboard		
All		ZERO function: possible only under stability condition, according to stability criterion <i>NOTE: The ZERO function allows to reset the gross measurement. It is only available if the measured value is included in +/- 10% of the full scale.</i>
		TARE function: possible only under stability condition, according to stability criterion <i>NOTE: The TARE value is the value subtracted from the gross measurement to get the net measurement.</i>
		PRESET TARE function <i>NOTE: A previous calculated TARE can be restored using this variable.</i>
		CANCEL TARE function <i>NOTE: Cancel TARE allows to switch back to the gross measurement display.</i>
		Shift to 2 nd keyboard
		Enter to Setup menu
		Access to thresholds adjustment screen (in Transmitter mode)
		Enter in the Quick Access Menu that give access to sensor input diagnosis and allows to set applicative target weights for eNod4-C, D, F and B. Quick access can be configured to manage what is accessible in this menu for eNod4-D and F.
		Weighing result acquisition (DSD) only in transmitter functioning mode.

eNod4-C		DYNAMIC ZERO function: Zero calculation (measurement averaging) without stability condition <i>NOTE: Dynamic ZERO function has the same result as the ZERO function except that the stability condition is not existing anymore (only measurement averaging).</i>
eNod4-D and F		SUSPEND DOSING: Allows suspending the ongoing dosing batch cycle. D : only possible when the “Suspend/Resume cycle allowed”. F : only possible when batch mode is activated. To resume the cycle touch, START CYCLE.
		MANUAL EMPTYING: D : Visible only in filling mode with Manual Emptying mode. Allows to activate the emptying logical output during the emptying phase. F : Start the extraction until the empty hopper level is reached.
eNod4-C, D, F and B		START CYCLE: C : Start Checkweigher cycle. D : Start the dosing cycle if starting conditions are satisfied. F : Start feeder cycle and the extraction. B : Start Belt dosing cycle. Invisible if process cycle is ongoing.
eNod4-D, F and B		STOP CYCLE: Stop the dosing cycle. The dosing counter is not incremented for eNod4-D.
eNod4-F		REFILLING: Allows starting manual refilling. A touch when refilling is ongoing stops the refilling. Visible only if hopper’s weight is under high refilling level. Any way refilling will stop automatically if hopper’s weight reaches high refilling level.
eNod4-B		DYNAMIC ZERO function: In belt mode and when the system is running, after receiving a “dynamic zero” command eNod4 calculates the average of integrated weight per length during the belt revolution time.
eNod4-B, F	 	STOP and RESTART PID at each cycle step.
eNod4-F and B		RESET TOTALIZATION: Reset the totalization value.

12.1.3.3 Diagnostic (available depending on version)

- The Quick Access diagnostic screen can be called directly from the main screen with the touch 
- The Diagnostic screen can be called using the key 

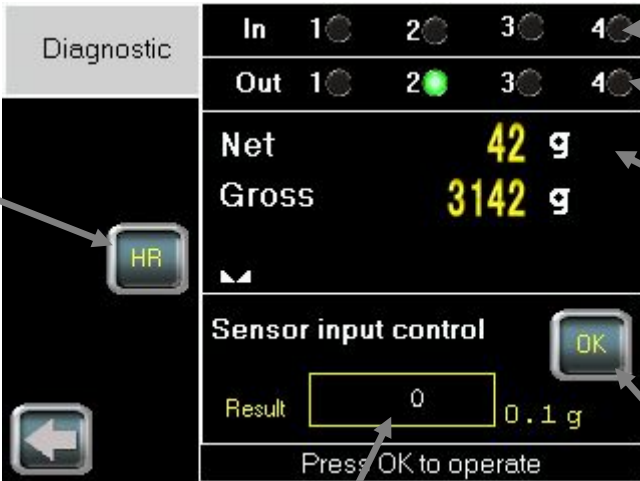

The screenshot shows the Diagnostic screen with the following elements and annotations:

- Logical inputs:** Four indicator lights labeled In 1, 2, 3, 4.
- Logical output:** Four indicator lights labeled Out 1, 2, 3, 4. Out 2 is currently lit green.
- Net weight:** Displayed as **Net 42 g** and **Gross 3142 g**.
- Sensor input control:** A section with a text input field showing '0' and a unit of '0.1 g'. Below it, it says 'Press OK to operate'. An **OK** button is to the right.
- HR (High-Resolution):** A button labeled 'HR' is shown on the left side of the screen.
- Navigation:** A back arrow button is at the bottom left.

NOTES:

- Sensor input reference must be performed before using the sensor input control functionality, see Sensor Input control Parameters menu in the Configuration Setup chapter.
- When you press the HR key, the High-Resolution net weight expressed in tenth of the user weight unit is displayed during 5 seconds. This may be used for weighing system metrological qualification.

12.1.4 Main setup menu

- eNodTouch setup menu allows to display and modify all the eNod4 parameters. For more information about parameters, consult eNod4 software manuals.
- Setup menu access can be secured by password (see § 3.5.1). In that case, the following screen is displayed:

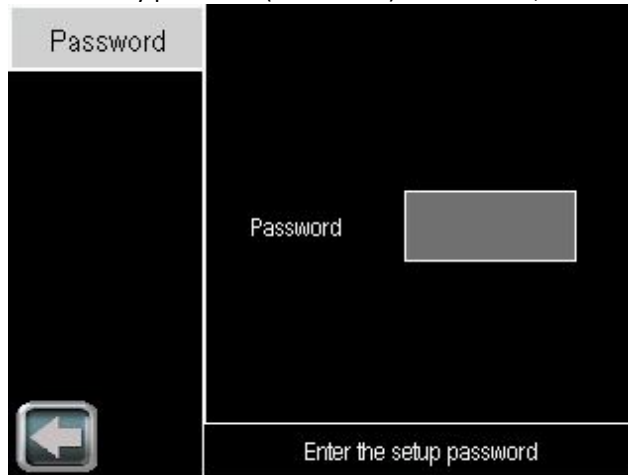

- After entering a valid password (or OLEG if you've forgot your password), the following menu will be displayed:

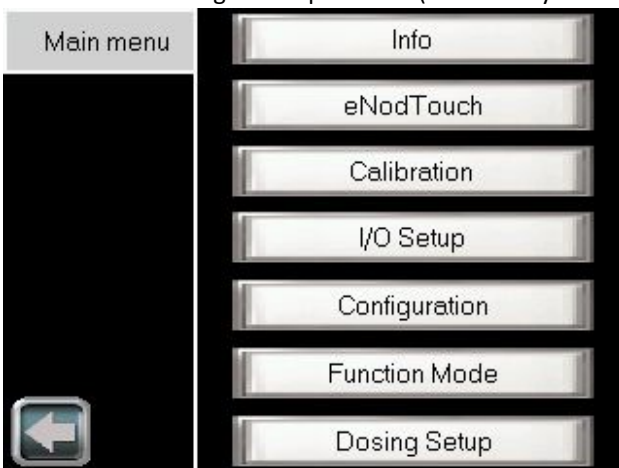

eNod4-D : Dosing Modes

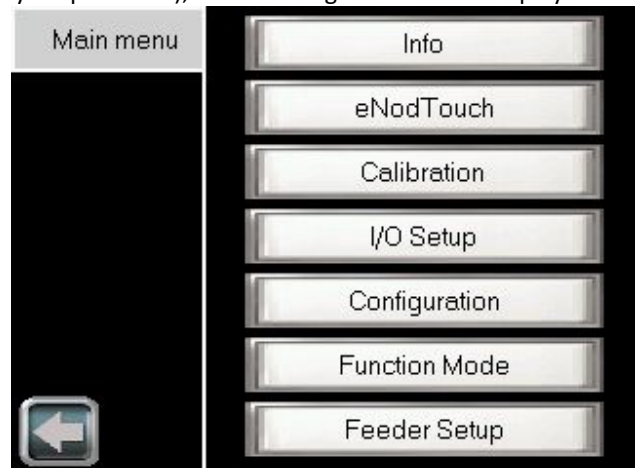

eNod4-F : Dosing Modes

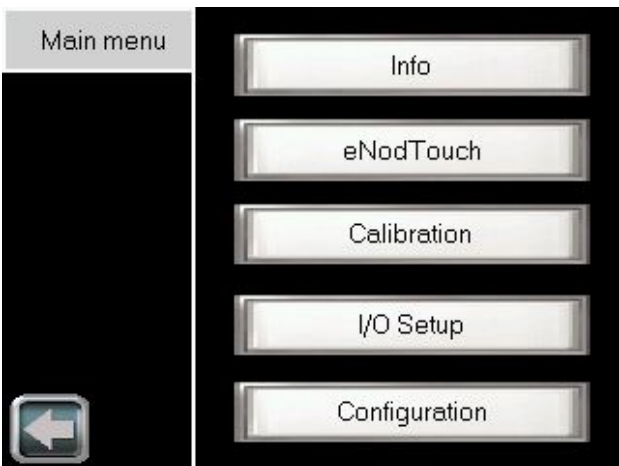

eNod4-T : Transmitter Mode

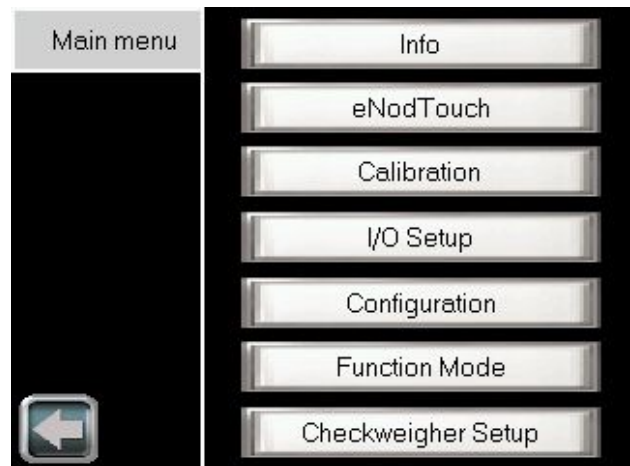

eNod4-C : Checkweigher Mode

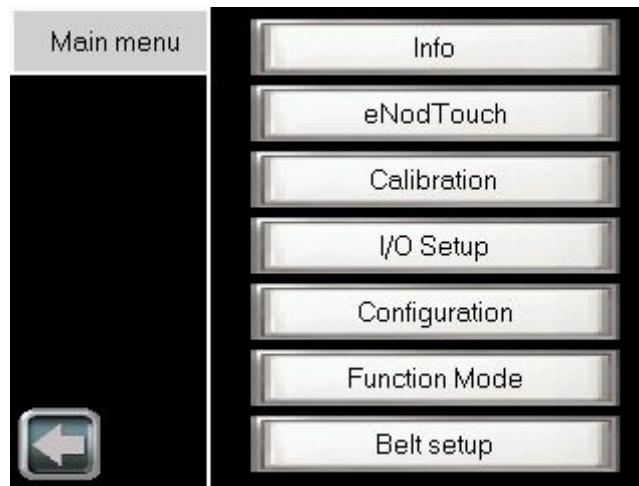

eNod4-B: Dosing modes

12.1.4.1 eNodTouch setup

Parameter	Possible Value	Description
-----------	----------------	-------------

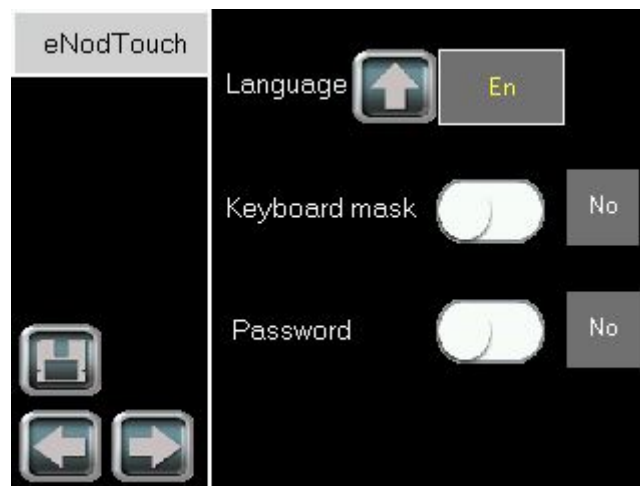

Language	[Fr], [En]	Change the language of eNodTouch software
Keyboard mask	[Yes], [No]	Enable/Disable keyboard display on main screen
Password	[Yes], [No]	Enable/Disable access protection to setup menu
	4 Char	By default, "OLEG" is a master password always valid

12.1.4.2 Starting parameters

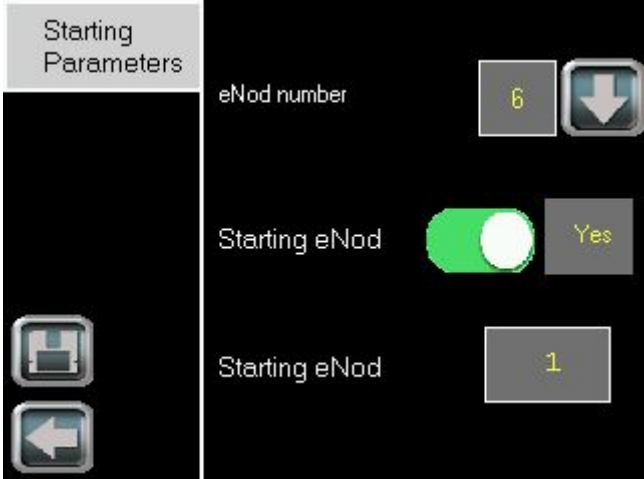
Parameter	Possible value	Description
		

eNod number	1-6	Number of eNod4 supported
Starting eNod	[Yes], [No]	Enable/Disable the function to start on main screen of a specific eNod
	1 – eNod Number	Number of starting eNod4. If there is only one eNod4 supported this function is necessarily activate.

12.1.4.3 Calibration Menu

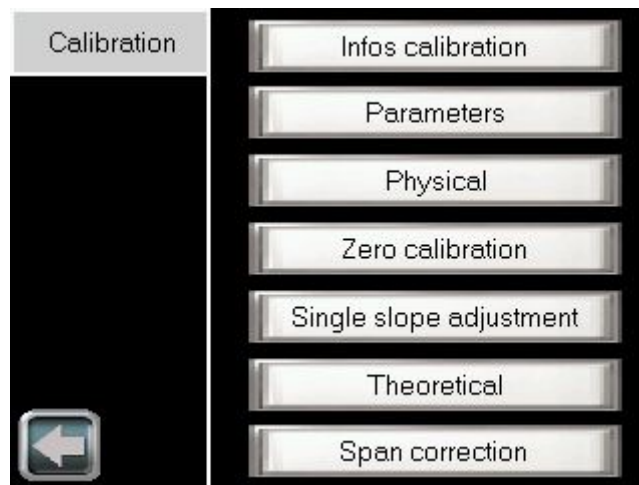

When using eNod4 for legal for trade purpose, it is imperatively required to activate the legal for trade switch BEFORE any calibration procedure (cf § legal for trade switch).

Parameter	Possible Value	Description
-----------	----------------	-------------

Calibration Parameters

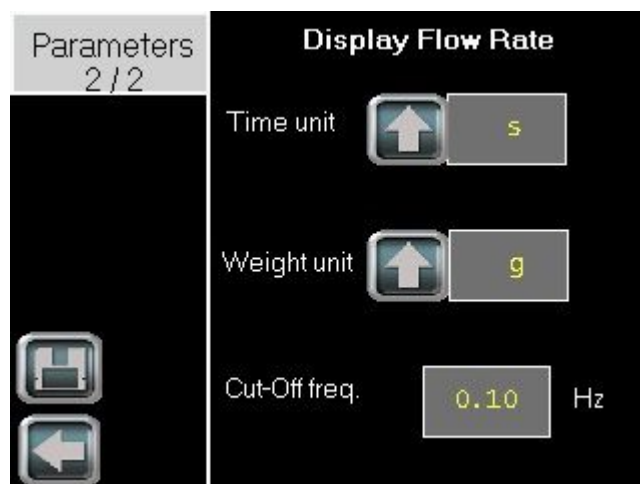
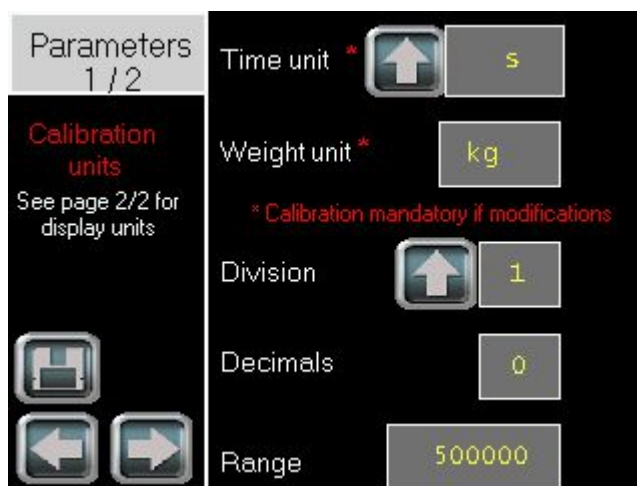

Range	0 – 10 000 000	Maximum weighing capacity
Division	1, 2, 5, 10, 20, 50	Difference between two consecutive indicated values
Decimals	0-7	Position of decimal point
Weight unit	4 visible char	Weight measurement unit (g, kg, t, lb...) using for calibration
Time unit	s, mn, h	Time unit using for calibration (eNod4-F and B). Only s and h can be selected in eNod4-B.
Weight unit (display flow rate)	g, kg, t	Weight unit of flow rate which is displayed on main screen.
Time unit (display flow rate)	s, mn, h	Time unit of flow rate which is displayed on main screen.
Cut-off frequency (display flow rate)		Cut-off frequency of flow rate which is displayed on main screen.

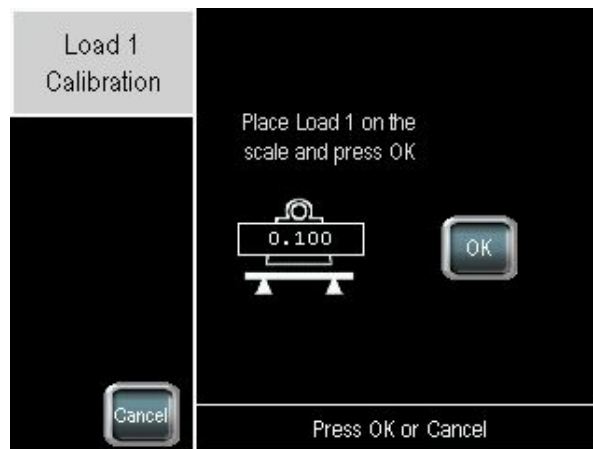
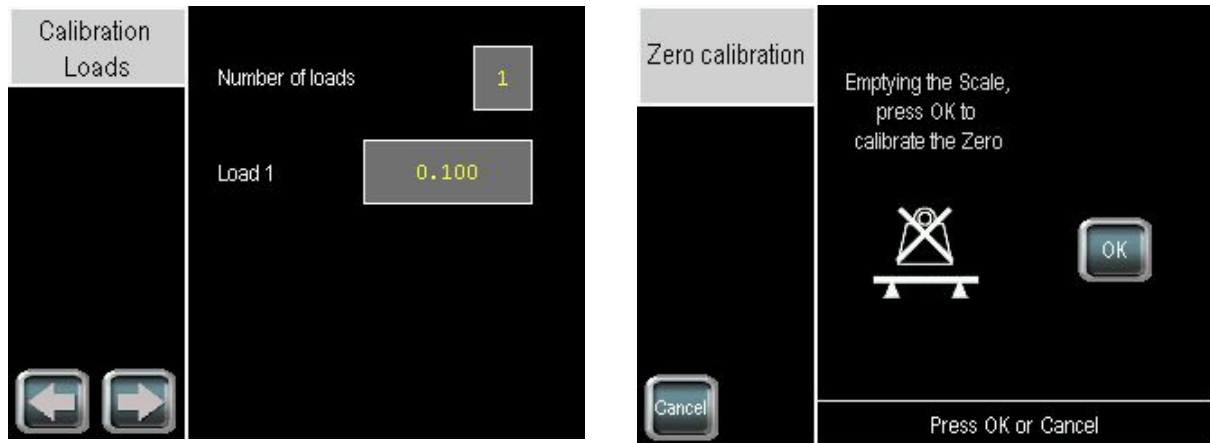

Physical calibration

Allows creating relation between the weighing sensor and the physical values.



Number of loads	1, 2, 3	Number of calibration loads used during the physical calibration.
Load 1/2/3	1 – 1 000 000	Weight values corresponding to each calibration segment.

The steps of this physical calibration operation are the followings :

1. Define the number of points to realize the calibration and the load values for each,
2. Press ,
3. Emptying the scale and press ,
4. Wait for the end of data acquisition,
5. Place the Load 1 and press ,
6. Wait for the end of data acquisition,
7. Repeat steps 5 and 6 (if several points have been defined).

Remark : If you press , the operation will stop and the values will not be saved.

The latest valid calibration values will be restored.

Zero Calibration

Allows acquiring stable measurement with no load on the scale to set the calibration Zero

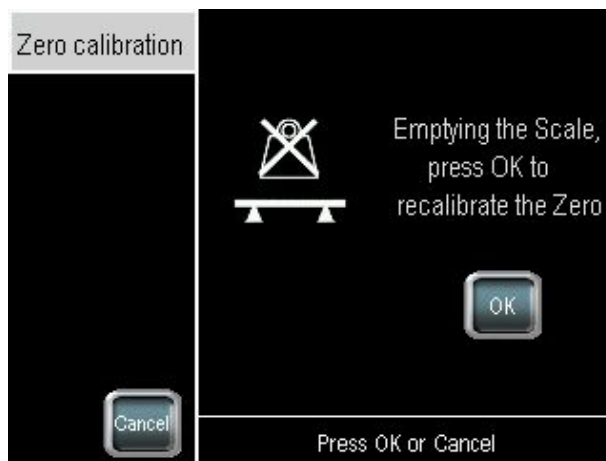

The steps of this zero calibration operation are the followings :

1. Emptying the scale and press ,
2. Wait for the end of data acquisition.

Remark : If you press , the operation will stop and the values will not be saved.



The latest valid calibration values will be restored.

Single slope adjustment

Allows acquiring stable measurement with a load on the scale to set the first segment. Performing physical calibration in this way do not allows multiple segments calibration. Use this calibration method only if you cannot acquire the segment calibration immediately after the Zero calibration (e.g.: big hopper). Zero calibration must have been done before.



The steps of this single slope adjustment operation are the followings :

1. Define the number of points to realize the calibration and the load values for each,
2. Press ,
3. Place the Load 1 and press ,
4. Wait for the end of data acquisition,
5. Repeat steps 3 and 4 (if several points have been defined).

Remark : If you press , the operation will stop and the values will not be saved.

The latest valid calibration values will be restored.

Theoretical calibration

An automatic scaling to migrate from the factory calibration to the user calibration.

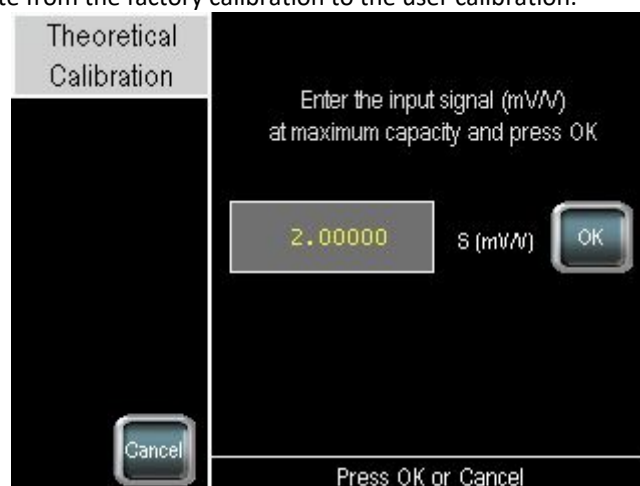

S (mV/V)

0 – 6.00000

Load cell sensitivity in mV/V at maximum capacity

Span Calibration correction

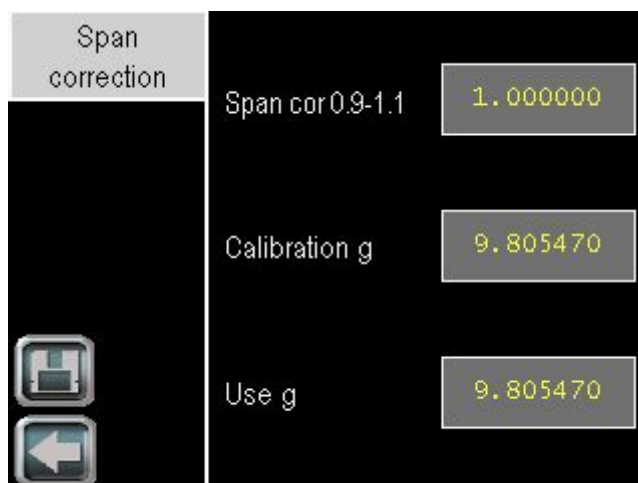

Span. cor	0.9 – 1.100000	Allows to adjust initial calibration
Calibration g	>0 (9.805470)	Allows compensating the gravity difference between calibration place and using place.
Use g	>0 (9.805470)	

12.1.4.4 I/O setup

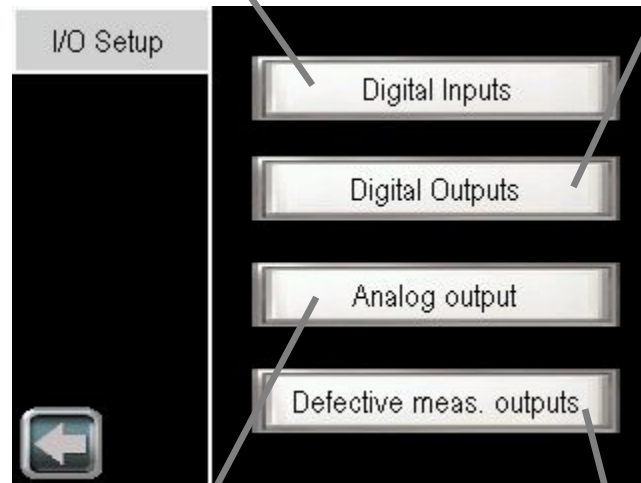
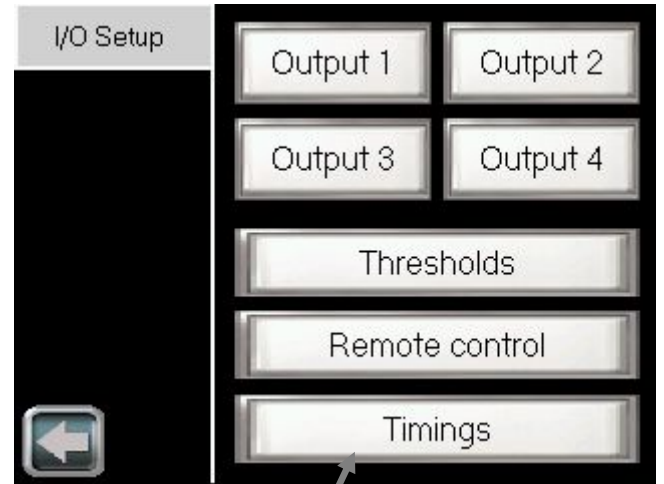
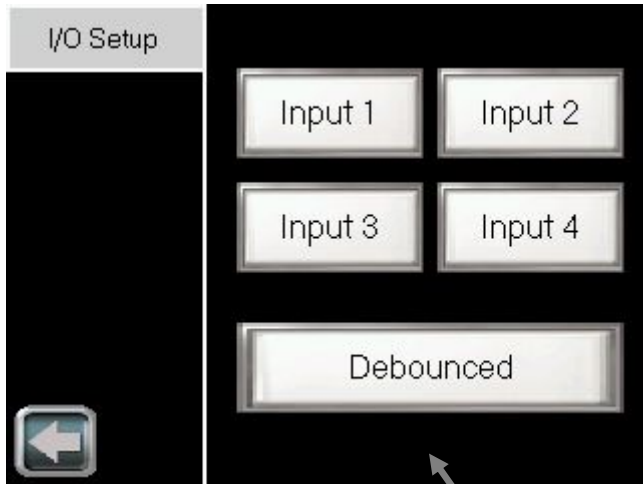

(IO+ version only)

(Available depending on version)

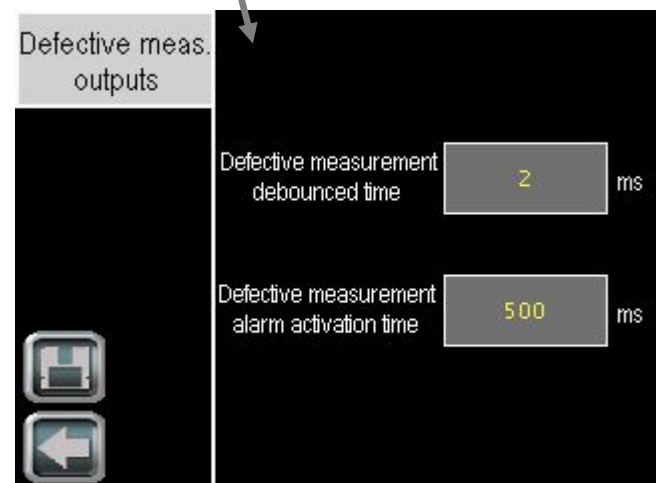
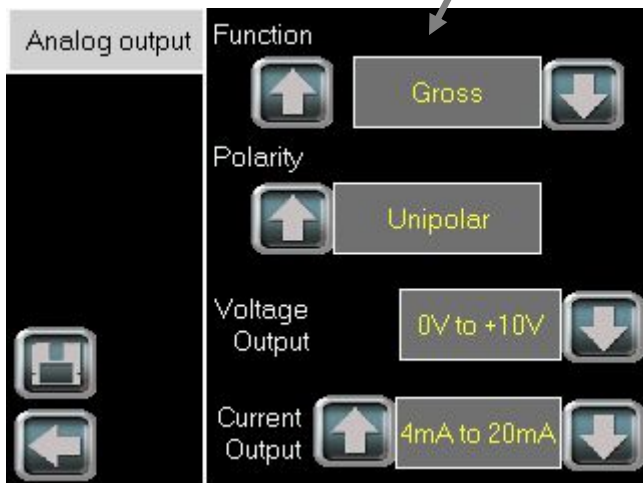

Parameter	Possible Value	Description
-----------	----------------	-------------

Input 1-4 Parameters

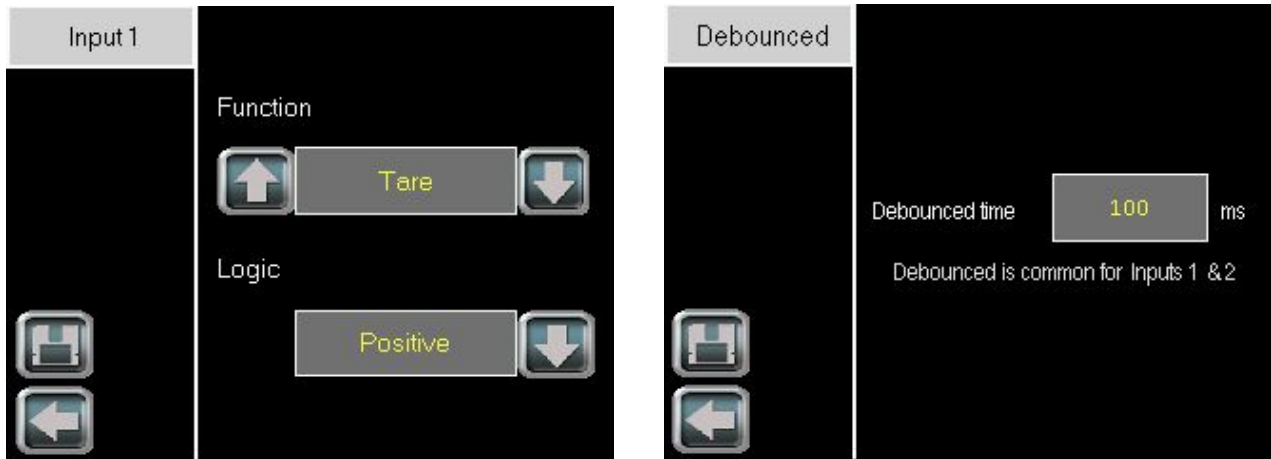

Function	Function assigned to the related input: None, Zero, Tare, Clear, start cycle, stop cycle, Suspend cycle, Dynamic Zero, Manual emptying, Belt fault	
Logic	[Positive]-[Negative]	defines the edge (or level) that triggers input function
Debounced time	0 – 6553 ms	Minimum required time of the logical inputs before their activation

Output 1-4 Parameters

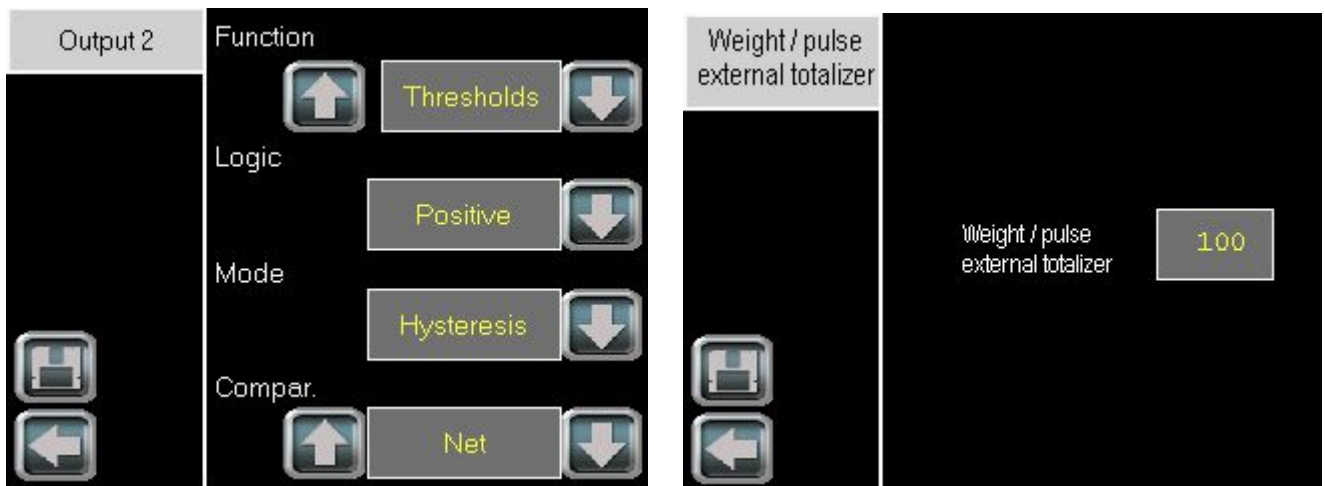

eNod4-F external totalizer (Page 2)

Function	Function assigned to the related output: None, Thresholds, Stability, Coarse feed, High feed, fine feed, Cycle ongoing, result available, Out of tolerance, Dosing fault, Input copy, Remote control, Out of tolerance +, Out of tolerance –	
Logic	[Positive], [Negative]	Defines idle output state.
Mode	[Windows], [Hysteresis]	Thresholds functioning principle
Comparison	[Gross], [Net], [result]	Comparison value for thresholds control
Weight / pulse external totalizer	0 – 65535	For external totalization purpose, eNod4 sends a pulse on logical output when the totalization value reaches multiple of this parameter. When an overflow is occurred on pulses output an alarm is set.

Thresholds control

Allows modifying the Threshold values of the concerned outputs.

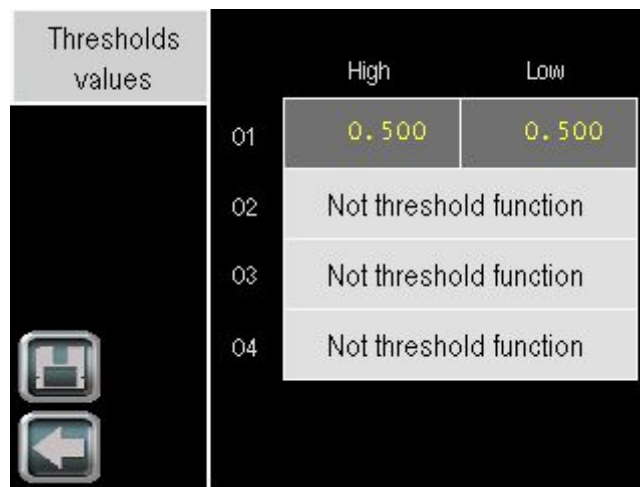

Remote Control

Allows fixing the level [On], [Off], of the concerned outputs.

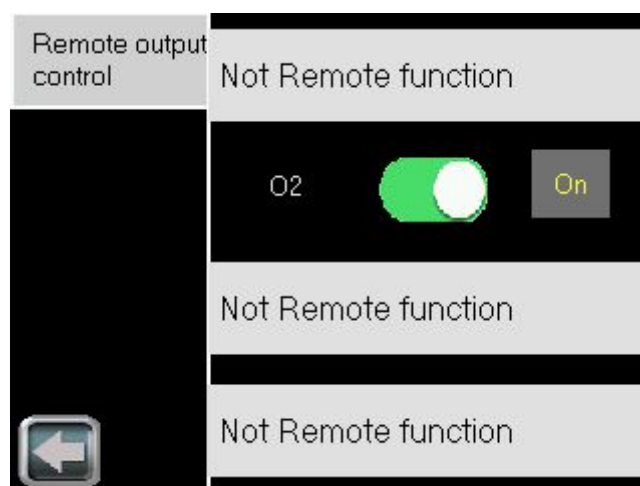

Outputs 1-4 timings

In Checkweigher, allows modifying timings on outputs with functions « Remote control » (activation time), « Result within tolerances » and « Result out of tolerances » (activation time and delay).

Timing control		activation (ms)	delay
01	NA	NA	
02	100	200	
03	NA	NA	
04	250	300	

Parameters Analog output (IO+ version only)

Analog output	Function	Analog output remote
	Gross	Remote Control value 0.00 %
	Polarity Unipolar	
	Voltage Output 0V to +10V	
	Current Output 4mA to 20mA	

Analog output remote (Page 2) with “remote control” function or “Flow Rate Ctrl” function

Flow Rate Ctrl
Min. Threshold 123 %
Ramp-up time 12345 s
Ramp-down time 12345 s

Fonction	The allocation of the analog output is unique for both outputs (current and voltage)	
Polarity	Bipolar / Unipolar	Analog outputs can be assigned to gross measurement copy. Maximal level value is related to maximum capacity (MC) parameter and works in mono-quadrant functioning. Bipolar option can only be applied to gross measurement copy. When this option is activated, the lowest value of current and voltage levels corresponds to -MC and the highest value to +MC.
Voltage Output	Voltage output might be set either 0-5V or 0-10V.	
Current Output	Current output to 4-20 mA, 0-24 mA, 0-20 mA or 4-20 mA alarm 3.6 mA.	

Defective measurement outputs parameters (Available depending on version)

Changes Defective measurement outputs timing.

An internal alarm flag reflects the integrity of the whole measurement chain. It's used to set logical output active or optional analog output in an error mode in order to warn about any deflection on the measurement chain (defective measurement).

This variable is set active when at least one of the followings conditions occurs:

- sensor input control results out of tolerances
- sensor input control command in progress
- sensor input control command failed (timeout)
- sensor input reference command in progress
- gross meas. < (- max capacity)
- gross meas. > (max capacity)
- analog signal out of the A/D converter input range
- EEPROM failure

This internal alarm flag is featured with adjustable specific de-bounced time and minimal activation time:

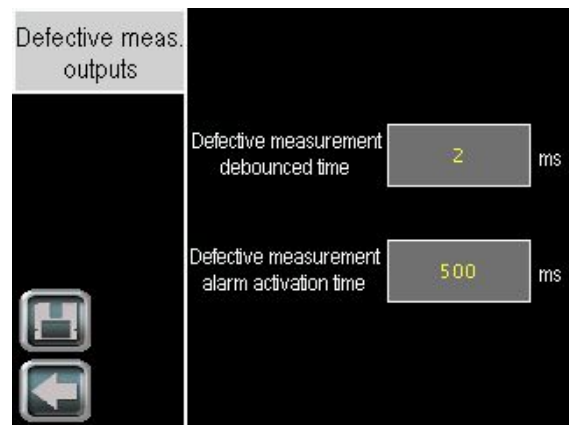

Defective measurement debounced time	0 – 65535 ms	The internal alarm flag which reflects the integrity of the whole measurement chain is set active only after error conditions have always been true during this de-bounced time.
Defective measurement alarm activation time	0 – 65535 ms	The internal alarm flag which reflects the integrity of the whole measurement chain remains active for this minimal “defective measurement alarm activation time” when it come to be active and whatever the error conditions are during activation.

12.1.4.5 Configuration setup

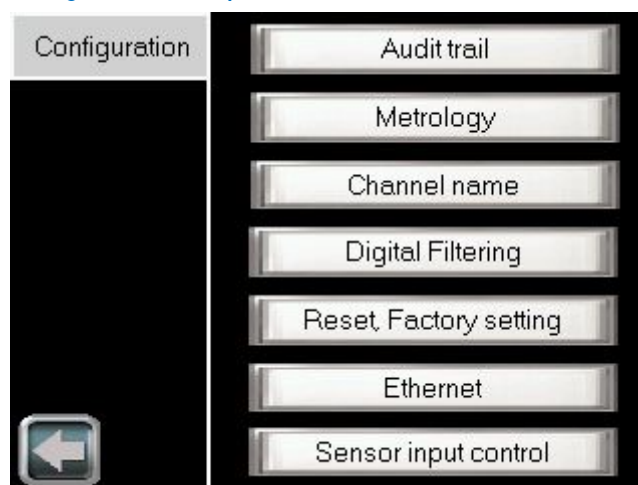

Parameter	Possible Value	Description
Metrology Parameters		



Stability criterion	None, 0.25 0.5, 1, 2d	Defines a stability interval, related to scale interval.
Zero at Startup	[Yes], [No]	Enable the Automatic Zeroing at power-on
Zero Tracking	[Yes], [No]	Enable the Zero tracking function
Legal for trade Switch (Available depending on version)	[Yes], [No]	<p>Enable the legal for trade mode.</p> <p>The prerequisite conditions for the activation of legal for trade mode are:</p> <ul style="list-style-type: none"> - The weight unit must be one of the following: mg, g, kg, t, ct, µg, oz. (possibility to put spaces after unit) - The stability criterion must be 0.25 d. - Filter settling time must be less than 1 second in transmitter mode. - The quotient (Maximum capacity / Scale interval) must be less or equal to 6000. - On eNod4-C, zero tracking device must not be activated together with dynamic zero tracking device. <p>On eNod4-T, C and D this mode has an effect on user calibration. Thus, this mode must be activated before processing any calibration.</p>
Save Tare in FRAM	[Yes], [No]	It allows saving tare in non-volatile memory (FRAM).
Save Zero in FRAM	[Yes], [No]	It allows saving zero in non-volatile memory (FRAM).

Audit trail (Available depending on version)



Legal for trade sealing	[Yes], [No]	Once legal for trade sealing activated, it forbids the change of any parameters that can affect the eNod4 metrological specifications. Such parameters appear in blue and are disabled over the eNodTouch menus.
Counter (audit trail)		This number is incremented on each legal for trade sealing switching.
Checksum		Checksum calculated over set of sealed parameters when legal for trade sealing is being activated.
eNod program version		Program version of eNod4 embedded software.
eNod metrological version		Version of set of metrological functions embedded in eNod4.
eNodTouch version		Program version of eNodTouch embedded software.
		Data Storage Device records consultation access.

Data Storage Device (Available depending on version)



Record ID to read		Record of the ID to be read.
		Erase all records from the DSD memory. This is possible only when the legal for trade sealing is disabled.

Ethernet Parameters (Ethernet versions only)

Ethernet

DHCP No

IP 192 168 0 100

Mask 255 255 255 0

Gateway 192 168 0 254

Swap data

Modbus TCP

Ethernet

DHCP Non

IP 192 168 0 100

Mask 255 255 255 0

Gateway 192 168 0 254

Ethernet/IP

Ethernet

IP 192 168 0 100

Mask 255 255 255 0

Gateway 192 168 0 254

Use rotary switch in Name (auto update Name on Save)

Name enod4-f-0x3

Byte order Little Endian

Profinet

IP	IP address
Mask	Subnet mask
Gateway	Default gateway (must match with IP address and Mask)
DHCP	Assignment of IP address from a DHCP server on this subnet
Swap data	Swap data (bytes) in Modbus TCP registers (16 bits words)
Name	Profinet station name (up to 10 chars with Option « Use rotary switch in Name » else 15, lower case, figures, dots and dashes only)
Option « Use rotary switch in Name »	Allows on Save automatic appending of hexadecimal representation of rotary switches in the Name.
Byte order	Byte order in Profinet exchanges ([Little Endian], [Big Endian])

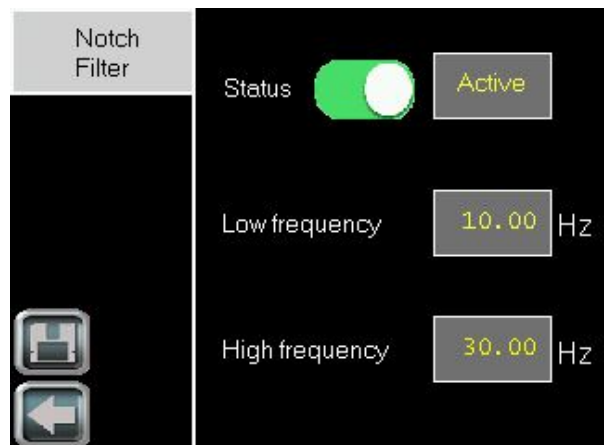
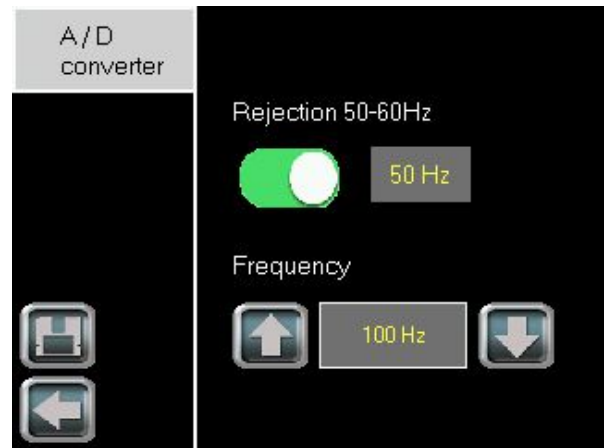

► **A/D converter parameters**

Rejection	[50Hz]-[60Hz]	The A/D converter have In-built adjustable low-pass filter with frequency rejection of 50 Hz or 60 Hz harmonics.
Frequency	6 – 1600 Hz	Filtered measurement frequency is adjustable from 6.25 to 1600 Hz

► **Bessel low-pass filter parameters**

Filter Order	0, 2, 3, 4	For the suppression of periodic vibrations, a Bessel low-pass digital filter can be applied as an output of the A/D converter.
Cut-Off Frequency	0.1 to 200Hz	Minimum cut-off frequency value depends on the A/D converter rate: 0.10 Hz for 6.25 meas/s, 4 Hz for 400 meas/s

► **Notch Filter parameters**

High & Low Frequency *	0.1 to 200Hz	Frequency band to attenuate with the digital Notch filter
-----------------------------------	--------------	---

* May not be implemented depending on eNod4 applicative version.

Reset, factory setting

Allows resetting eNod4 or making eNod4 come back to factory settings

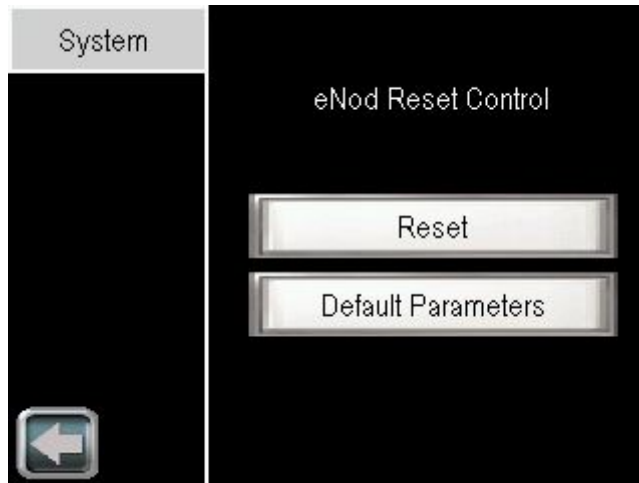

Channel name



Name or rename the channel with a maximum of 4 characters

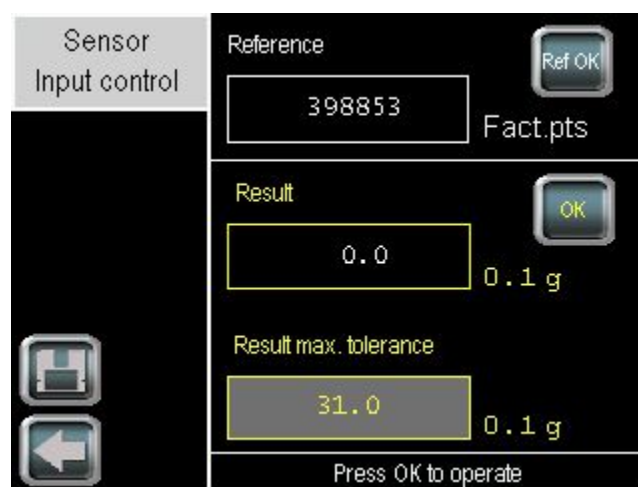

Parameter	Possible Value	Description
-----------	----------------	-------------

Sensor Input Control Parameters (Available depending on version)



Reference		Reference value expressed in factory calibrated points for the sensor(s) input control test. The value is automatically determined and stored after executing the sensor input reference command.
Result		Result of sensor(s) input control test expressed in 1/10 of user weight unit. Its value is automatically determined and stored after executing the sensor input control command. This test result represents the weight difference between the reference value and the current test value.
Result max. tolerance	0.0 – 6553.5	The Sensor input control result variable is compared with the Sensor input control result max. Tolerance parameter which is expressed in 1/10 of user weight unit and has a default value of 30. If the sensor input control result value is greater than or equal to “Sensor input control result max. Tolerance” then an error is reported
		Sensor input control command will cause eNod4 to handle special test on sensor input and to deliver a test result. This command must not be realized when any process cycle that use weight is in progress.
		Sensor input reference command will cause eNod4 to handle special sequence to acquire sensor input control reference value of the load cell sensor input. This command must be performed before using the Sensor input control command and each time the weight measurement chain (sensor, connection, calibration) is modified. This command must not be realized when any process cycle that use weight is in progress.

12.1.4.6 Functioning mode (eNod4-C, D, F, B)

- According to the eNod4 model, the following screen is displayed to select the functioning mode

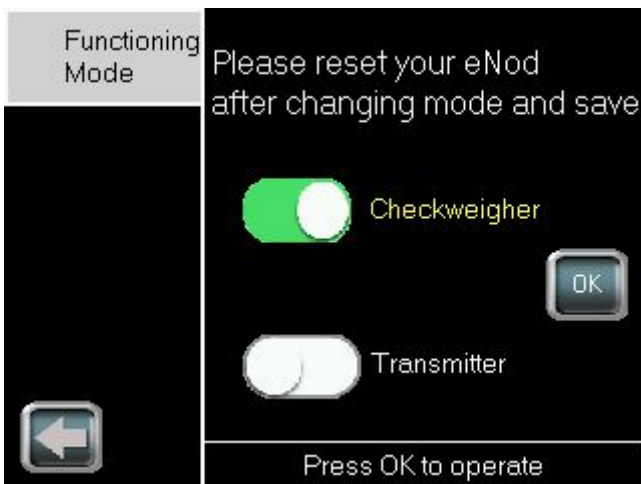

eNod4-C

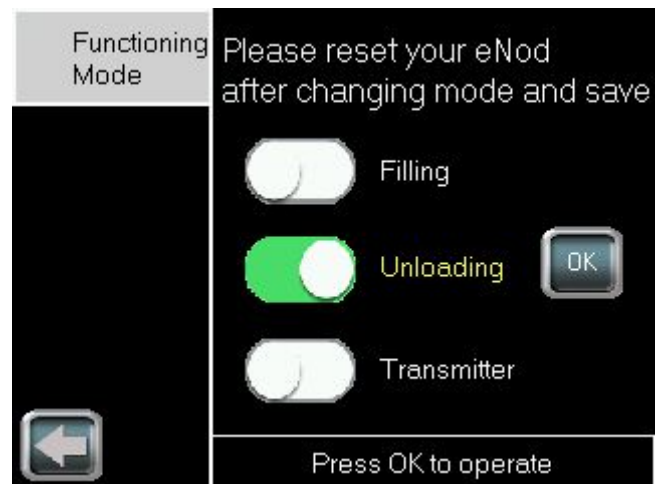

eNod4-D



eNod4-F

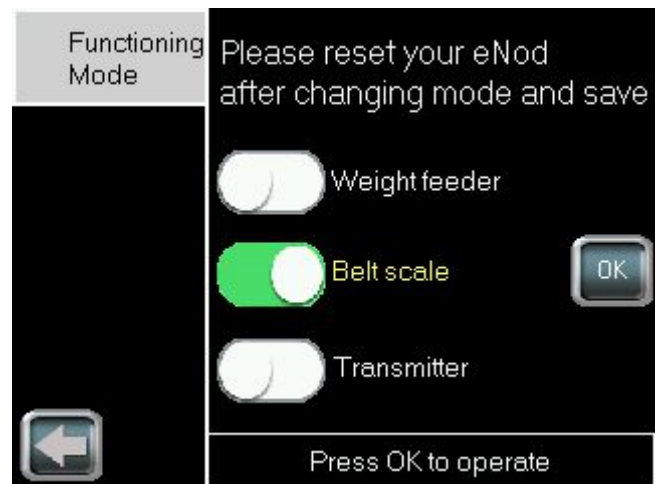

eNod4-B

12.2 Belt parameter configuration (eNod4-B)

- Detailed explanations on Dosing functioning and parameters could be found into eNod4-B manuals
- The following setup menu allows modifying the parameters related to Belt setup.

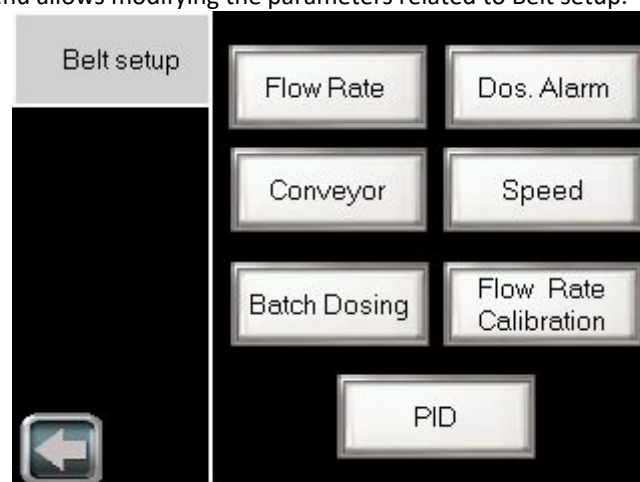

12.2.1 Flow Rate

Parameter	Possible Value	Description
Flow Rate Parameters		



Nominal Flow Rate		Set point flow rate expressed in weight unit per time unit. eNod4 determines nominal belt load from nominal speed and nominal flow rate.
Avg flow rate and speed deter depth	0 - 128	Defines the samples “n” numbers for moving average filter on flow rate and belt speed.
Weight / pulse external totalizer	0 – 65535	For external totalization purpose, eNod4 sends a pulse on logical output when the total value reaches multiple of this parameter. When an overflow is occurred on pulses output an alarm is set.

- To access the correction touch

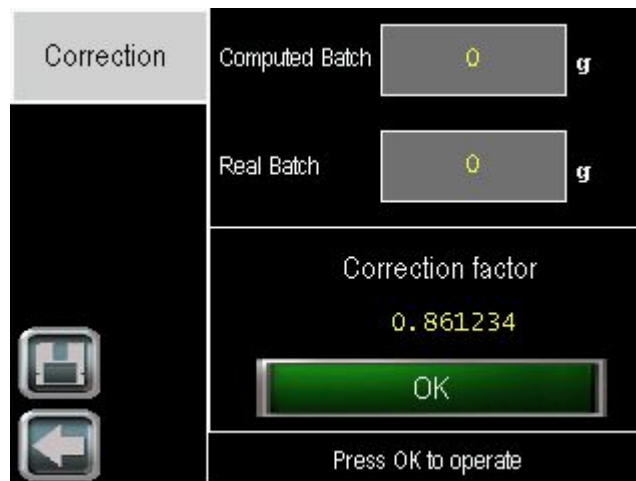

Computed Batch		Last Batch result (RO)
Real Batch	0 – 99999999 g	After material test, user must fill the real batch measured by a measurement instrument before sending flow rate correction command.
		<p>Correction factor can be used to correct deviations in the total dosed amount by compensating for mechanical variations. At receiving a “flow rate correction” command eNod4 recalculate a correction factor by calculating:</p> $\text{New Correction} = \text{Correction} \times \frac{\text{Checked Batch Total}}{\text{Current batch total}}$ <p>The next batch the Batch Total and Checked Batch Total should be closer together.</p> <p><i>Important: Before initiated this command, user has to configure the “Real Batch” parameter.</i></p>

12.2.2 Dosing Alarms

Parameter	Possible Value	Description
Dosing Alarms Parameters		

Dosing alarms 1 / 4

Min permissible * instant flow rate % of nominal flow rate

Max permissible * instant flow rate

Min permissible flow rate control output % of nominal flow rate

Max permissible flow rate control output

* disabled if 0



Dosing alarms 2 / 4

Min permissible * conveyor speed % of nominal speed

Max permissible * conveyor speed

Min permissible * conveyor load % of nominal load

Max permissible * conveyor load

* disabled if 0



Dosing alarms 3 / 4

Inhibit time flow rates * load alarms at start s

Inhibit time flow rates * load alarms in service s

Inhibit time speed * alarm at start s

Inhibit time speed * alarm in service s

* disabled if 0



Dosing alarms 4 / 4

Inhibit time belt fault * alarm at start s

Inhibit time belt fault * alarm in service s

Stop/Susp. dosing on alarms default No

* disabled if 0



► Page 1/4

Min permissible * instant flow rate	0 – 6553.5	Minimum value for flow rate for alarm function.
Max permissible * instant flow rate	0 – 6553.5	Maximum value for flow rate for alarm function.
Min permissible flow* rate control output	0 – 6553.5	Minimum value for control output for alarm function.
Max permissible flow* rate control output	0 – 6553.5	Maximum value for control output for alarm function.

► Page 2/4

Min permissible * conveyor speed	0 – 6553.5	Minimum value for belt speed for alarm function.
Max permissible * conveyor speed	0 – 6553.5	Maximum value for belt speed for alarm function.
Min permissible * conveyor load	0 – 6553.5	Minimum value for belt load for alarm function.
Max permissible * conveyor load	0 – 6553.5	Maximum value for belt load for alarm function.

► Page 3/4 et 4/4

Inhibit time flow rates * load alarms at start	0 – 65535 sec	Monitoring the flow rate or belt load is only activated after this delay time when the belt is started. It is expressed in second.
Inhibit time flow rates * load alarms in service	0 – 65535 sec	When the flow rate or belt load is below/above the min / max value, the alarm is activated after this delay elapsed. It is expressed in second.
Inhibit time speed * alarm at start	0 – 65535 sec	Inhibition time at belt start of speed monitoring in second.
Inhibit time flow rates * load alarms in service	0 – 65535 sec	Inhibition time in service of speed monitoring in second.
Inhibit time belt fault alarm at start	0 – 65535 sec	Inhibition time at belt start of belt fault monitoring in second.
Inhibit time belt fault alarm in service	0 – 65535 sec	Inhibition time in service of belt fault monitoring in second.
Stop/Susp. dosing on alarms default	Yes / No	Stop totalization function if alarm occurred

12.2.3 Conveyor

Parameter	Possible Value	Description
Conveyor Parameters		

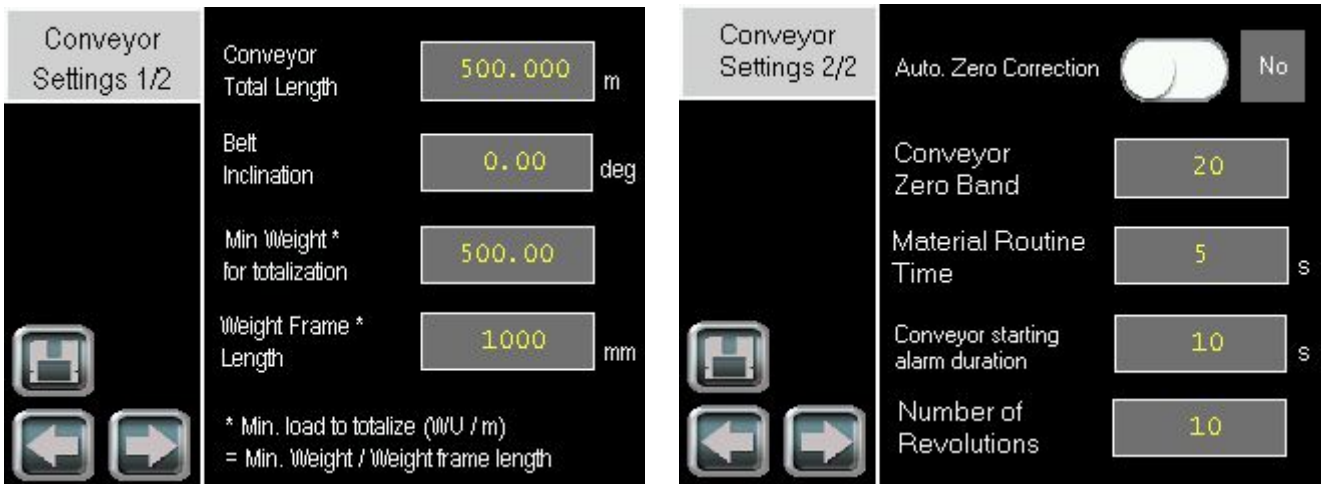

► **Page 1/2**

Conveyor total Length		Defines the total length of the belt in meters.
Belt Inclination	0.00 – 35.00 deg	Defines the belt title angle in degrees.
Min Weight * For totalization	0.00 – 655.35	eNod4 enables totalization when “minimum weight to totalize” divided by “weight section length” is greater than the minimum load to totalize.
Weight Frame * Length	0 – 65535 mm	Represents the effective belt weigh frame length expressed in millimeters. The effective weight section length corresponds with half of the distance between the belt rollers which are found before and after the roller with the belt scale.

► **Page 2/2**

Auto. Zero Correction	Yes / No	Dynamic zero auto-correction activation
Conveyor Zero Band	0 - 65535	Defines limit values for dynamic zero correction function. Zero function is cancelled when the weight is out of these limits.
Material Routine Time	0 – 6535 sec	Defines time for materials to travel distance from shear gate to weigh section at normal speed.
Conveyor starting alarm duration	0 – 3500 sec	For security reason, eNod4 provides buzzer function on logical output at belt start. The buzzer duration depends on this parameter value in second.
Number of Revolutions	1 - 65535	Specifies the real belt revolutions to realize during speed/length calibrations and dynamic zero procedure.

- The Band Length Calibration is available on page 2 of the 'Conveyor Settings' pressing

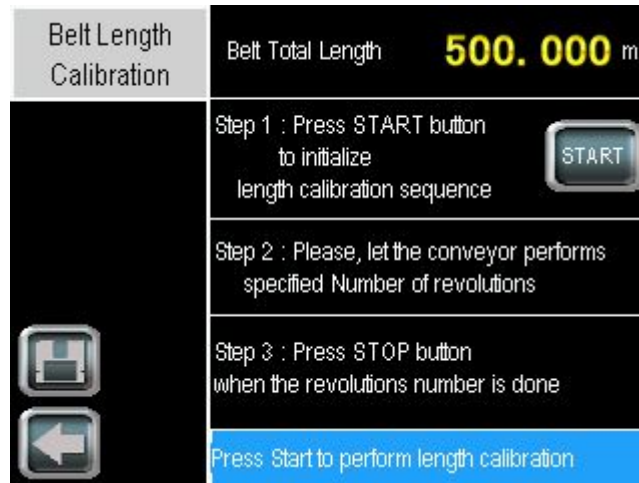

When the system is running empty, this command will cause eNod4 to initiate belt length calibration sequence. An internal timer is restarting and the calibration procedure duration will depend of the current belt speed, the belt length and the number of revolutions to handle.

Important: Before initiated belt length calibration procedure, user has to configure the following parameters:

- Maximum pulses per meter (see next §)
- Number of revolutions

12.2.4 Speed

Parameter	Possible Value	Description
Speed Parameters		



Speed Target	0.00 – 655.35 m/s	Defines the nominal speed in m/s. eNod4 determines nominal belt load from nominal speed and nominal flow rate.
Speed stabilization time at start	0 – 65535 sec	In weigh feeder mode and if PID function is done through the belt speed, this is the stabilization time before PID activation.
User fixed Speed *	0.00 – 655.35 m/s	Defines the belt speed in m/s if no speed sensor is connected to eNod4.
Maximum pulses per meter	0 - 65535	Defines constant maximum pulses number of speed sensor.
Speed determination time factor	1 – 65535 (250ms)	Specifies the belt speed determination time in multiple of 250ms.

- The Speed Calibration is available on page 2 of the ' Speed Settings ' pressing

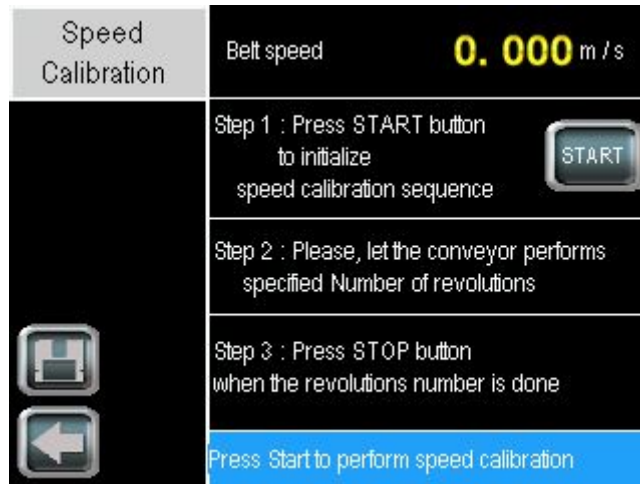

When the system is running empty, this command will cause eNod4 to initiate belt speed calibration sequence. An internal speed sensor pulses counter is restarting and the calibration procedure duration will depend of the current belt speed, the “total belt length” and the “number of revolutions” to handle.

Important: Before initiated speed calibration procedure, user has to configure the following parameters:

- Conveyor total Length
- Number of revolutions

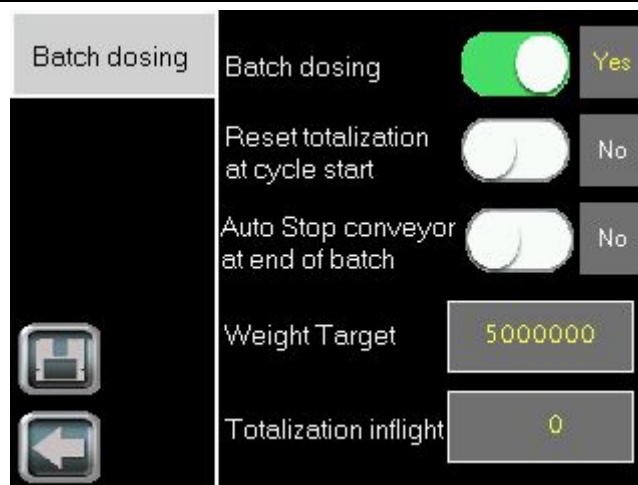

12.2.5 Batch dosing

Parameter	Possible Value	Description
Batch dosing Parameters		



Batch dosing	Yes / No	Allows the dosing stop automatically when the accumulated weight reaches the weight target less totalization inflight value.
Reset totalization at cycle start	Yes / No	When this option is activated the totalization is cleared each time a new cycle starts.
Auto Stop conveyor at end of batch	Yes / No	When this option is activated the dosing cycle is stopped automatically when the accumulated weight reaches the weight target less totalization inflight value.
Weight target	0 – 9999999.9	The batch target in weight unit
Totalization inflight	-9999999.9 – 9999999.9	The batch target inflight value in weight unit.

12.2.6 PID

Parameter	Possible Value	Description
PID parameters		
		

PID activation	Yes / No	eNod4 adjusts the speed of the extraction device to produce a constant flow rate and to comply with flow rate target setting.
Behavior	Slow / Fast / Stable	eNod4 is fitted with an automatic adjustment device of the PID parameters. Slow, Fast or stable behaviour can be selected.
PID adjustment Flow Rate		Flow rate value that will be used for the automatic adjustment of PID parameters.
Kp		Proportional coefficient of the PID controller that drives the extraction device. An increase of this parameter will degrade stability, reduce the rise time and increase the overshoot.
Ti	0 - 65535	Integration time constant of the PID controller that drives the extraction device, expressed in ms. An increase of this parameter will reduce the steady state error but will degrade stability and increase time rise and overshoot.
Td	0 - 65535	Derivate time constant of the PID controller that drives the extraction device. Adding some derivate can improve time rise and overshoot. The great majority of extraction devices don't accept derivate correction or a very low value for the derivate term.
		Launch automatic adjustment of PID. So that this controller automatic adjusting device works, both the weight calibration and the flowrate calibration must be previously carried out. PID parameters auto-adjustment command will cause eNod4 to perform successive dosing cycle (10) sequences to calculate optimized PID coefficients Kp, Ti and Td.

12.2.7 Flow Rate Calibration

Parameter	Possible Value	Description
Flow Rate Calibration parameters		

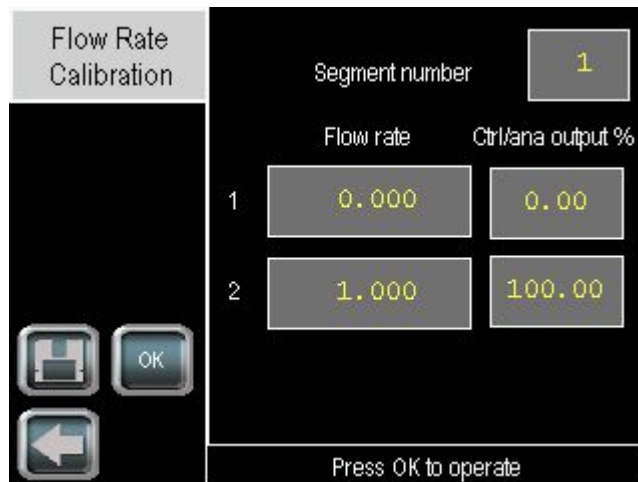



Segment number	1 - 9	When the flow rate of an extraction device has a non-linear response in function of the flow rate output control, up to 9 segments can be configured.
Flow Rate		Flow rate point corresponding to Ctrl/analog output point. Expressed in flow rate unit. Up to 10 calibration points can be configured.
Ctrl/ana output %	0 - 100	PID controller output data (activated or not) drives current or voltage outputs generally coupled to the extraction device. Data is expressed in % of the high value of current or voltage analog outputs. Maximal level output value corresponds to the maximal flowrate.
		Validate the flow rate calibration. Mandatory to make this flow rate calibration active.

The steps of this flow rate calibration are the followings :

1. Set the control output to the mode 'Remote control' (see § 'Input/Output settings'),
2. Define the number of segments to perform the calibration,
3. For each point, enter the desired value for the control output (in %),
4. For each point, set the control output to the entered value and report the measured flow rate values (Visualization of the flow rate on the main screen or through eNodView application),

5. Press  to validate this calibration (save in volatile memory).

6. Press  to store in non-volatile memory the values entered.

Note : the arrows,  and  allow navigation between screens and back to the previous menu.